

\$4.00



communications

**OPERATING and SERVICE
INSTRUCTIONS**



the hallicrafters co.

MANUFACTURERS OF ELECTRONIC EQUIPMENT, CHICAGO 24, U. S. A.



092-005184

Figure 1. Hallicrafters SX-101 Receiver

SECTION I GENERAL

Your new Hallicrafters SX-101 Selectable Sideband Receiver is precision built to bring you the finest in amateur radio reception. This fifteen tube dual conversion superheterodyne receiver tunes the 160, 80, 40, 20, 15 and 10-11 meter amateur bands plus several of the MARS frequencies on a large 10-1/2 inch slide-rule type dial. You'll hear many difficult amateur signals which would not be readable on most other receivers. The receiver provides for the reception of CW, AM, and single-sideband signals on all bands, the upper or lower sideband being readily selectable by means of a front panel control. This selectable sideband feature not only greatly simplifies tuning of single-sideband signals but is also useful in eliminating heterodyne interference when receiving AM signals.

Unlike the ordinary dual-conversion receiver, your SX-101 receiver employs dual conversion on all bands. As a result, images are practically non-existent. "Razor-sharp" selectivity is made possible by the use of an adjustable 50.5 kc second IF with four high-Q, permeability-tuned circuits. Receiver selectivity is variable in five steps from 500 cycles to 5 kc at 6 db down and from 5 to 20 kc at 60 db down.

A tuned r-f stage assures maximum sensitivity and a high signal-to-noise ratio for outstanding reception of weak and distant signals. A manual sensitivity control prevents overloading by strong signals. An antenna

trimmer, adjustable from the front panel, permits peaking of the r-f stage to compensate for loading effects of various antennas. A notch filter circuit allows rejection of an extremely narrow portion of the IF passband. With the notch filter, an interfering signal can easily be "notched out". The position and the degree of notch rejection are adjustable from the front panel.

Outstanding frequency stability is achieved by the use of concentric air trimmers and ceramic coil forms in the 1st conversion oscillator, extensive temperature compensation, voltage regulation of all oscillators, and the use of a crystal-controlled 2nd conversion oscillator.

Tuning is accomplished by a precision gear drive tuning mechanism to insure extremely close calibration and accurate resetability. Smooth flywheel tuning affords maximum traverse speed and operating ease. The tunable portion of the receiver is designed to spread each amateur band over most of the dial, for easy and accurate tuning. Dial graduations are provided for 5kc on the 160, 40, 20, and 15 meter amateur bands. On 80 meters there is a dial graduation for every 10 kilocycles, and on the 10-11 meter amateur bands there is a dial graduation for every 50 kilocycles. A built-in 100-kc crystal calibrator provides marker signals at every 100kc on the dial for checking calibra-

tion accuracy. A trimmer capacitor, accessible from the top of the chassis, permits adjustment of the calibrating oscillator to exactly 100 kc by comparison with the frequency transmitted by station WWV on ten megacycles. Band 7 of this receiver is for tuning in WWV for the purpose of zero-beating the 100-kc crystal calibrator.

An automatic series noise limiter circuit, controlled by a switch on the front panel, effectively reduces interference from electrical equipment, ignition noise, and other forms of pulse type noise.

An "S" meter is used when receiving AM signals to indicate the accuracy of tuning and the relative strength of received signals. The meter is calibrated in microvolts, "S" units from 1 to 9, and in decibels above S9 to +80 db. Unlike most receivers, the "S" meter is operative when AVC is turned off, and thereby renders the same tuning accuracy indication as when the AVC is turned on.

In SSB operation, with no signal input, the "S" meter will give a reading in "S" units between 6 and 8, however, upon signal input, the "S" meter will properly indicate the signal level above its resting value.

The Receive-Standby switch on the front panel silences the receiver but leaves the heater and plate power on to provide instant reception between transmission periods. Provision has also been made in the receiver for remote receive-standby control, and for transmitter switching from the front panel.

Audio output connections include terminals for a 3.2-ohm speaker and a 500/600-ohm output for line or speaker. A front panel jack for headphones is also provided. A phono input jack at the rear of the receiver permits attachment of a record player.

Band 7 on the receiver is used to check and adjust the 100 kc calibration oscillator. This is accomplished by tuning in the ten-megacycle WWV signal and comparing it with the calibration oscillator signal.

A heating element (Dampp Chaser) has been incorporated in the receiver to provide optimum performance by reducing the effects of moisture and humidity.

Electrically, the heating element and oscillator filament transformer are wired across the AC line. Thus, both will be on at all times while the receiver is connected to a 117V AC outlet, even when the Response Control is in the Power-Off position.

NOTE

IT IS IMPORTANT THAT THE RECEIVER BE PLUGGED IN A LIVE OUTLET AT ALL TIMES IN ORDER TO OBTAIN OPTIMUM RESULTS FROM THE HEATING ELEMENT. THE EXCELLENT DESIGN INCORPORATED IN THIS SET WILL BE REALIZED ONLY AFTER IT HAS BEEN PLUGGED INTO SUCH AN OUTLET A MINIMUM OF 24 HOURS.

SECTION II INSTALLATION

2-1. UNPACKING

After unpacking the receiver, examine it closely for damage which may have occurred in transit. Should any sign of damage be apparent, file a claim immediately with the carrier stating the extent of damage. Carefully check all shipping labels and tags for instructions before removing or destroying them.

2-2. LOCATION

The receiver may be placed in any location that will permit free air circulation through the ventilation holes and openings in the cabinet. Avoid excessively warm locations such as those near radiators and heating vents. The external speaker may be located in any convenient position although it is recommended that it not be placed on top of the receiver for reasons of ventilation.

2-3. ANTENNAS

The r-f input of the receiver is designed for operation from either a single-wire antenna, or a half-wave

doublet or other tuned antenna. The design of the input circuit is versatile to permit the use of transmission lines having an impedance up to 600 ohms. Optimum matching will be effective however, when using transmission line having an impedance in the range of 50 to 70 ohms. Antenna connections are made to a three-terminal strip at the rear of the receiver marked "A1", "A2", and "G". An AN type SO-239 connector for coaxial cable installations is also provided.

A. SINGLE WIRE ANTENNA

The simplest antenna and one which will provide satisfactory results throughout all bands is a conventional single-wire antenna. In most localities, good results can be obtained with just the 15-foot of antenna wire. (See Fig. 2.) Simply attach one end of this wire to terminal "A1", connect the jumper link between terminals "A2" and "G", and then run the wire about the room in any convenient manner. If the receiver is operated in a steel constructed building or where receiving conditions are exceptionally poor, an outside antenna, 50 to 100 feet

long may be necessary. The outside antenna should be erected as high as possible and kept free from surrounding objects. In some locations, reception may be improved by connecting a ground wire (ordinary copper wire) from terminal "G" to a cold water pipe. While the use of an outside ground rod installed in accordance with Insurance Underwriter's Laboratories requirements is adequate protection against lightning, we strongly recommend an additional connection to the nearest cold water pipe to eliminate any shock hazard.

B. HALF-WAVE DOUBLET ANTENNA

For top performance on a particular amateur band, the use of a half-wave doublet or other type of antenna employing a 50 to 70 ohm transmission line is recommended. A typical doublet antenna installation is shown in Fig. 3. The overall length in feet of a doublet antenna is determined by the following formula:

$$\text{Length in feet} = \frac{468}{\text{Frequency in megacycles}}$$

The doublet antenna is directional and should be erected with its entire length facing a desired station for maximum signal pickup.

The doublet antenna may be fed with either a balanced or unbalanced transmission line. When a balanced line such as "twin-lead" or a twisted pair is used, the line connects to terminals "A1" and "A2" and the jumper link between "A2" and "G" is disconnected (see Fig. 3). When using an unbalanced line such as coaxial cable, the inner conductor connects to terminal "A1", the outer metal braid to terminal "A2", and the jumper link connects between terminals "A2" and "G". A ground wire may improve reception when using an unbalanced type line.

The doublet antenna provides optimum performance only for the amateur band for which it is cut. Therefore, when using such a doublet antenna, it may be desirable for reception on other amateur bands to utilize the antenna as a single wire type. This is accomplished by connecting the two transmission line leads together and connecting them to terminal "A1". The jumper link in

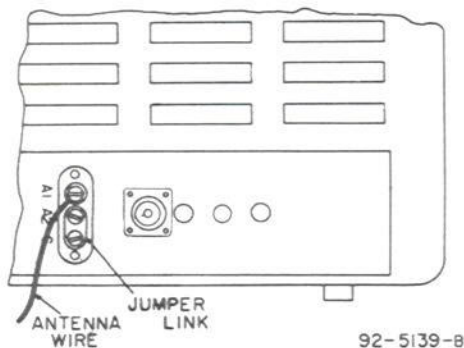

Figure 2. Single Wire Antenna

this case should be connected between terminals "A2" and "G".

In an installation where the receiver is used in conjunction with a transmitter, it may be advantageous to use the same antenna for receiving as for transmitting. This is especially true when a directive antenna is used since the directive effects and power gain of the transmitting antenna are the same for receiving as for transmitting. Switching of the antenna from the transmitter to the receiver may be accomplished with a double-pole, double-throw antenna changeover relay or knife switch connected in the antenna leads.

For further information regarding receiving antennas and antenna matching schemes, refer to the "Radio Amateur's Handbook" or the "A.R.R.L. Antenna Book", both published by the American Radio Relay League, West Hartford, Conn., U.S.A.

2-4. POWER SOURCE

The receiver is designed to operate on 105 to 125 volt, 50-60 cycle AC current. Power consumption is 115 watts.

IMPORTANT: If in doubt about your power source, contact your local power company prior to inserting the power cord into an AC power outlet. Plugging the power cord into the wrong power source can cause extensive damage to the unit, requiring costly repairs.

2-5. SPEAKER

A three-terminal strip, marked "G", "3.2" and "500", is provided at the rear of the receiver for connecting the external speaker that is required with the receiver. (See Fig. 4.) Any permanent magnet speaker with a 3.2-ohm voice coil can be used by simply connecting the two leads from the speaker voice coil to the terminals marked "3.2" and "G". If it is desired to use a speaker with a voice coil impedance other than 3.2 ohms, a matching transformer should be employed to insure optimum performance. The transformer should

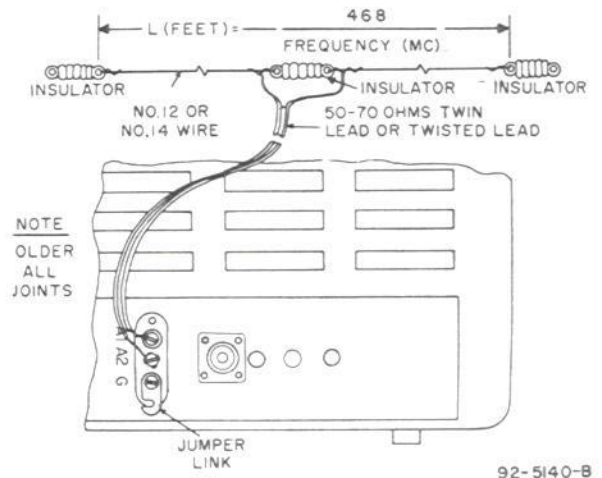

Figure 3. Doublet Antenna Using Twin-Lead Transmission Line

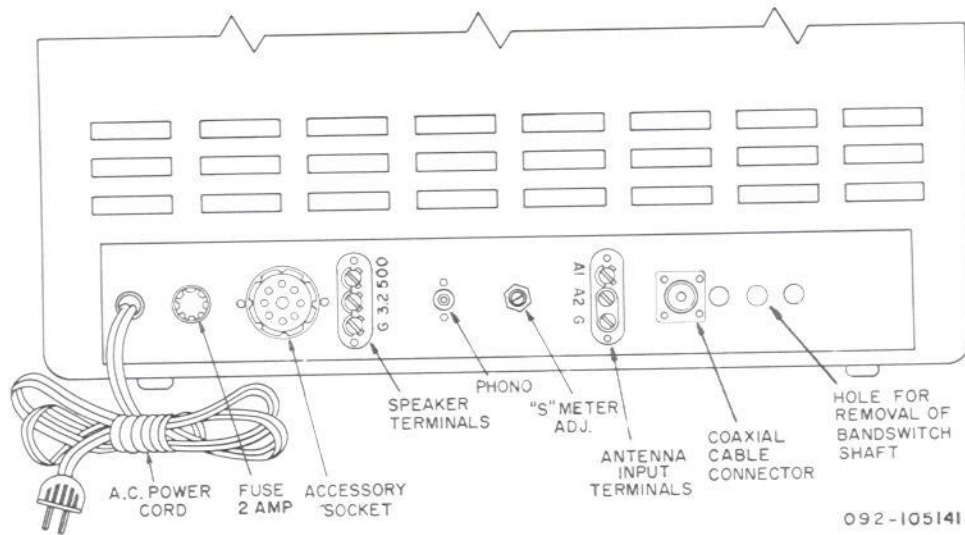

Figure 4. Rear View of Receiver

be mounted on or near the speaker, and should have a 5-watt power rating, a 500-ohm primary impedance, and a secondary impedance to match the impedance of the speaker voice coil. Connect the primary of the transformer to the terminals marked "500" and "G" and the secondary to the speaker voice coil terminals.

The Hallicrafters R-46B and R-47 speakers are both designed for use with your receiver. Either speaker may be connected to the terminals marked "3.2" and "G".

2-6. HEADPHONES

The headphone jack, marked PHONE, is located on the front panel of the receiver and is so wired that the 3.2 ohm speaker terminal is automatically silenced when the headphones are inserted. The headphone output impedance is not critical, and any commercial

low-impedance headphones ranging from 50 ohms to 5000 ohms will provide satisfactory performance. The 500 ohm speaker tap is connected at all times.

2-7. RECORD PLAYER CONNECTIONS

A phono jack is provided at the rear of your receiver for attaching a record player. (See Fig. 4.) Any record player using a crystal cartridge - or a magnetic cartridge with suitable preamplifier - will provide satisfactory results. For phono operation, insert the pin-plug from the record player or preamplifier into the phono jack and set the SELECTIVITY control on the front panel at "PHONO". Adjust the VOLUME control for the desired volume level and set the RESPONSE control at either "NORMAL" or "TREBLE CUT" for the desired tone. The remaining controls are inoperative and will have no effect on phono operation.

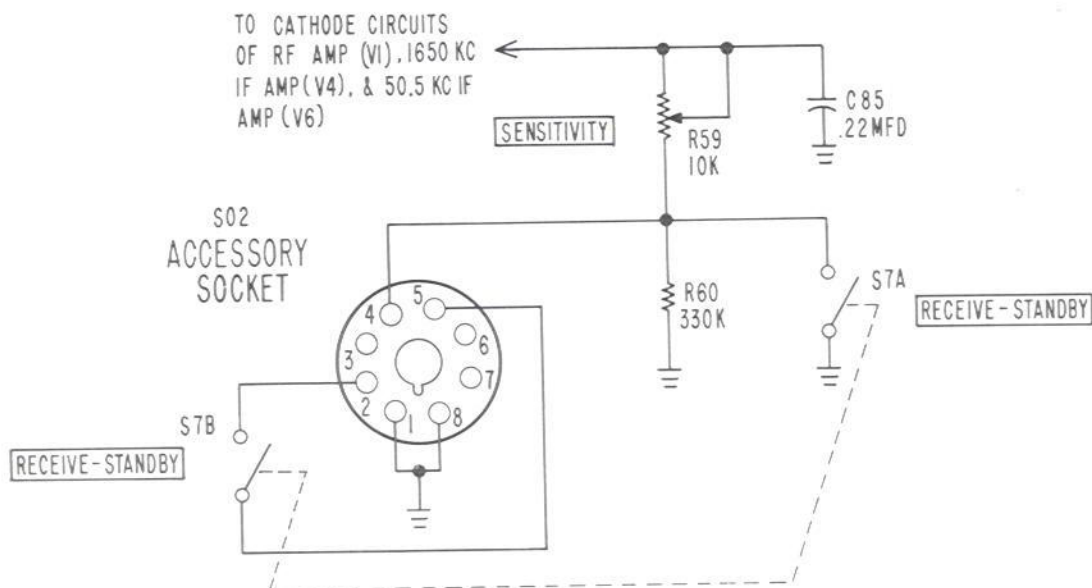

092-202377-B

Figure 5. Schematic Diagram of Sensitivity and Receive-Standby Circuits

2-8. RELAY AND TRANSMITTER SWITCHING

One half of the dpst RECEIVE-STANDBY switch on the front panel connects to pins 2 and 5 of the ACCESSORY SOCKET at the rear of the receiver, and is available for transmitter switching. (See Fig. 5.) This half of the switch is in the open position when the RECEIVER-STANDBY switch is set at "STANDBY" and closed when set at "RECEIVE".

2-9. REMOTE RECEIVE-STANDBY SWITCH

The receiver may be disabled from a remote location by connecting a remote spst switch between pins 1 and 4 of the JUMPER PLUG located in the ACCESSORY SOCKET at the rear of the receiver. (See Fig. 4 and 5.) To operate the receiver with the remote switch, the RECEIVE-STANDBY switch on the front panel must be left at "STANDBY".

SECTION III FUNCTION OF OPERATING CONTROLS

3-1. SENSITIVITY CONTROL

The SENSITIVITY control varies the gain of the RF amplifier, 1650-kc IF amplifier, and the 6BA6 50.5-kc IF amplifier stages. Maximum sensitivity is obtained with the control set at "10" (fully clockwise). In this position, the tubes being controlled are operated at maximum gain with minimum cathode bias. As the control is rotated counterclockwise, the bias on the tubes increases with a resultant decrease in gain.

3-2. BAND SELECTOR CONTROL

The BAND SELECTOR control operates the band switch to place the proper set of coils and capacitors into the circuit to cover the desired amateur band. The band covered by each position of the BAND SELECTOR control is indicated directly on the control. The first six positions are the 160, 80, 40, 20, 15 and 10-11 meter amateur bands, respectively. The seventh position tunes in the 10-mc WWV signal, and is indicated on the 10-11 meter scale with a special marking. This band is available for calibrating the 100-kc crystal calibrator.

3-3. ANTENNA CONTROL

The ANT. TRIMMER control operates a variable capacitor connected across the secondary of the antenna coil of the band in use. This capacitor adjustment compensates for loading effects of various types of antenna installations. The control is adjusted for maximum signal after the tuning control is adjusted to the desired frequency. Once adjusted, the ANT. TRIMMER control usually requires no further adjustment until the BAND SELECTOR control is operated to select another amateur band.

3-4. VOLUME CONTROL

The VOLUME control adjusts the audio level at the

speaker terminals and PHONE jack. Clockwise rotation of the control increases the signal applied to the grid of the audio amplifier tube, thus increasing receiver volume; counterclockwise rotation decreases volume. In some cases when receiving CW or SSB signals, it may be advantageous to advance the VOLUME control one-half to three-quarters clockwise, and control receiver volume with the SENSITIVITY control.

3-5. AVC SWITCH

The AVC switch, when set at "ON", places the AVC circuit in operation to maintain the output level of the receiver constant regardless of normal input-signal variations. AVC voltage is applied to the RF amplifier stage and the 1650 kc IF amplifier stage.

3-6. "NOISE LIMITER" SWITCH

This switch, when set at "ON", places the automatic series noise limiter circuit in operation to reduce pulse type noises such as ignition noise and electrical interference. The limiter circuit is effective on AM reception, which allows the signal to pass through the receiver unaffected, but makes the receiver inoperative for noise amplitudes greater than those of the signal.

The noise limiter circuit "chops" noise peaks received at the detector by means of a biased diode which becomes non-conducting above a predetermined signal level. When the limiter circuit is in operation, the audio output of the detector must pass through the limiter diode to the grid of the audio amplifier. The limiter diode normally acts as a conductor for the audio signal as long as the diode plate is positive with respect to its cathode. When a noise peak is higher in amplitude than the signal, it instantaneously swings the cathode positive with respect to the plate, conduction ceases, and that portion of the signal is automatically cut off from the audio amplifier. The point at which

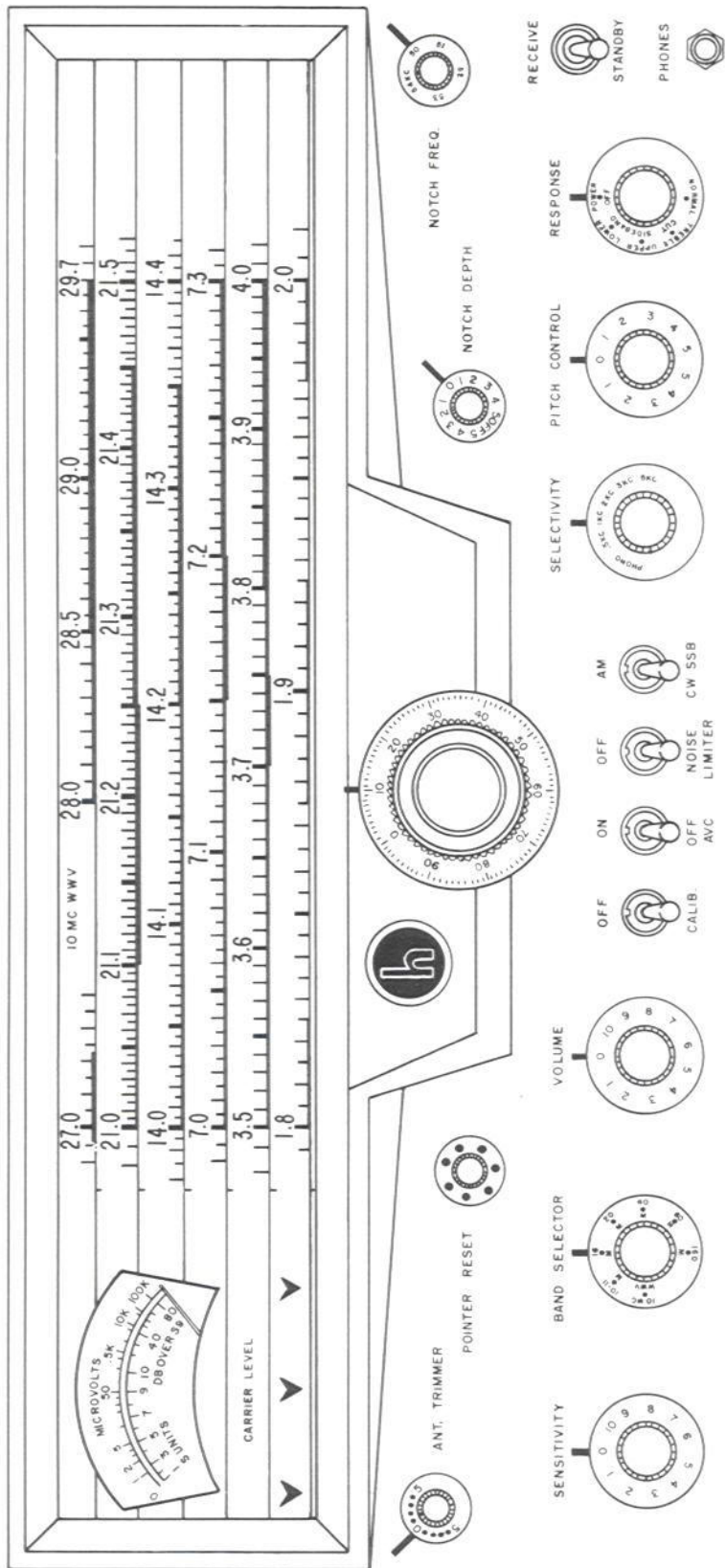

the hallicrafters co.

MODEL SX-101

Figure 6. Operating Controls

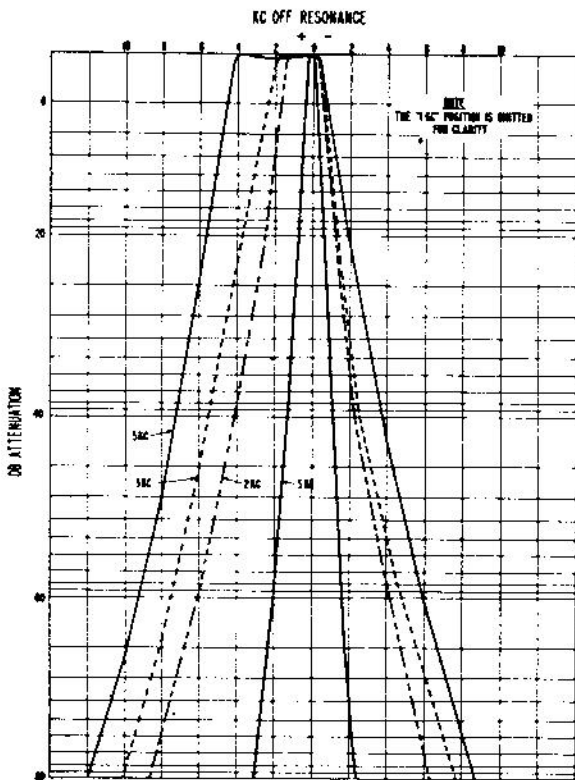

Figure 7. IF Selectivity Curves

the limiter diode becomes non-conducting is made sufficiently high so that the diode will not clip modulation peaks and thus impair intelligibility, but yet low enough to limit the noise peaks effectively.

This type of efficient noise limiter circuit greatly reduces "listening fatigue" which can accompany long periods of reception.

3-7. "AM/CW-SSB" SWITCH

This switch, when set at "CW-SSB", applies plate voltage to the beat frequency oscillator (BFO) to render it operative for the reception of CW or single-sideband signals. The beat frequency oscillator employs a Hartley oscillator circuit and its voltage regulated to insure highly stable operation. The "AM" position of the AM/CW-SSB switch disables the BFO for normal reception of AM phone signals.

3-8. "SELECTIVITY" CONTROL

The SELECTIVITY control is used to vary the selectivity of the receiver to fit receiving conditions. Five degrees of selectivity are available, ranging from 500 cycles, for CW reception under crowded amateur band conditions, to 5 kilocycles for maximum fidelity when amateur band conditions permit. The five selectivity positions are indicated on the SELECTIVITY control and indicate receiver selectivity at 6 db down. A sixth position on the control, marked PHONO, disables all the receiver circuits except the audio system. The output from a simple radio detector circuit connected to the PHONO INPUT will permit the use of the audio system for the reception of Conehrad radio signals.

The detector must be capable of receiving 640 kc and/or 1240 kc.

As mentioned above, and when conditions permit, the SELECTIVITY control is normally set at 5 KC, the position affording broadest selectivity. Selectivity may be progressively increased and passband decreased by turning the control to the positions marked "3 KC", "2 KC", "1 KC", and ".5 KC". For reception of the crowded amateur bands, it is generally advisable to sacrifice some fidelity for greater selectivity, since the added selectivity reduces both adjacent-channel interference and background noise by attenuating the higher audio frequencies. Too much selectivity on AM signals, however, will attenuate the high audio frequencies to such an extent that the signal may become unintelligible as a result of excessive sideband cutting. When receiving CW signals, the sharpest selectivity position may be used without the loss of intelligibility experienced in AM reception.

3-9. "T" NOTCH FILTER

The notch filter circuit provides a means of eliminating or reducing the interfering effect of certain types of heterodynes or CW signals. To obtain maximum results from this feature of your receiver the use of the two controls associated with the notch filter circuit are fully explained below.

GENERAL

The manner in which the notch filter will affect the IF selectivity of the receiver is illustrated in Fig. 8. The filter will suppress an extremely narrow band of frequencies within the IF bandpass range of the receiver. The effectiveness of this notch is many times greater than the notch of a quartz crystal filter at 400 kc to 2 mc. The NOTCH FREQ. control will move the band of suppressed frequencies represented by the notch in the selectivity curve, to any point within the IF passband. The NOTCH DEPTH control will vary the depth of the notch in the selectivity curve to control the degree of rejection of the interfering signal.

Extensive field testing of this feature has shown that the notch filter is highly effective in suppressing the type of interference for which this type of circuit is intended. It must be appreciated, however, that any selective IF filter circuit, including the phasing notch of quartz crystal circuits, affects only a limited range of interfering frequencies. The effectiveness of the notch filter is therefore somewhat dependent upon the exact nature of the interfering signal. For example: a heterodyne within the IF range that is less than 900 cycles in width and has little harmonic content is readily notched out. If the same interfering heterodyne is rich in harmonics it would only be possible to completely suppress the fundamental frequency and the remaining harmonic content may remain almost equally objectionable. It logically follows that if two interfering heterodynes should appear within the IF passband that are separated in frequency by more than 500 to 900 cycles it would be possible to notch out only one of the heterodynes. The interfering signal may also vary in frequency beyond the range of the notch filter and thus reduce the effectiveness of the circuit. Under these conditions, increasing selectivity will generally eliminate its heterodyne. If this heterodyne interference varies in frequency about some mean value it may be

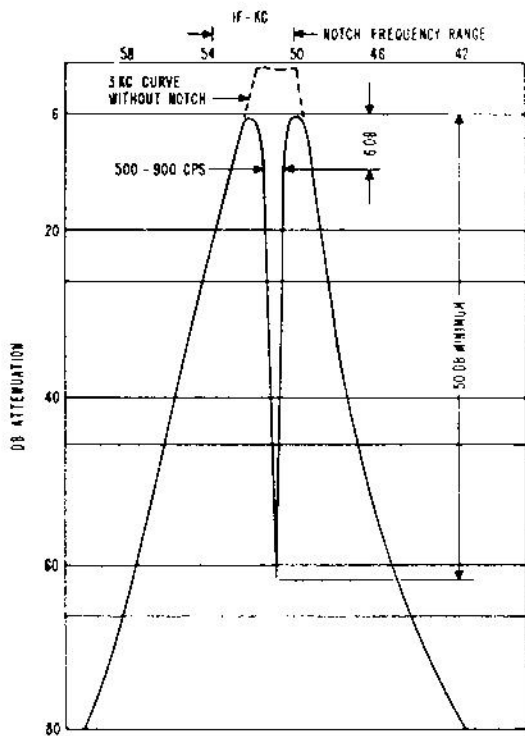

92-5015

Figure 8. IF Selectivity Curve with Notch

necessary to adjust the NOTCH DEPTH control to increase the broadness of the notch. It has been found, however, that the notch filter is sufficiently effective in many instances to make an otherwise useless signal entirely readable.

3-10. USE OF CONTROLS

To activate the Notch Filter circuit advance the NOTCH DEPTH control from the "OFF" position.

"NOTCH FREQ.," CONTROL—This control tunes the notch in the IF passband and may be set anywhere in the range of from 50 kc to 54 kc. The approximate frequency is calibrated on the knob skirt. While tuning this control for maximum suppression of the interfering heterodyne with minimum distortion to the desired signal, try to visualize the notch moving across the selectivity curve, Fig. 8. It is then readily apparent that improper tuning may notch out the desired signal instead of the heterodyne. It may be necessary to move the notch across the desired signal in order to reach the heterodyne that you desire to suppress. The important consideration is to tune the NOTCH FREQUENCY control for maximum heterodyne suppression with minimum distortion to the desired signal.

"NOTCH DEPTH" CONTROL—As the position of the NOTCH FREQ. control is changed, the depth of the notch will vary. The NOTCH DEPTH control is provided to readjust the notch for maximum depth at any setting of the NOTCH FREQ. control. Maximum notch ing occurs at the "O" setting when the frequency is set to the center of the IF passband. The use of the NOTCH DEPTH control is simply a matter of tuning it for maximum suppression each time the position of the NOTCH FREQ. control is changed.

3-11. PITCH CONTROL

The PITCH CONTROL operates the tuning slug in the BFO coil to vary the frequency of beat frequency oscillator approximately 2 kc each side of its center frequency of 50 kc. The primary function of the PITCH CONTROL is to vary the pitch of the audible beat note when receiving CW signals. It is also used when receiving single-sideband signals to vary the frequency of the reinserted carrier in the receiver.

3-12. "RESPONSE" CONTROL

The RESPONSE control performs three functions: (1) it turns the receiver on and off, (2) it switches the 2nd conversion oscillator to operate at the required frequency for reception of CW, AM, and single-sideband signals (1600 kc in the "LOWER SIDEBAND" position and 1700 kc in the "UPPER SIDEBAND", "TREBLE CUT", and "NORMAL" positions), and (3) it serves as a two-position tone control for AM reception and phono operation.

In the "POWER OFF" position, the receiver is completely shut down except for the Damp Chaser and oscillator filament transformer. As the control is turned clockwise to any of the other four positions, the receiver power is turned on.

The "LOWER SIDEBAND" and "UPPER SIDEBAND" positions of the control are used when receiving single-sideband signals or when it is desired to receive one or the other sideband of an AM signal.

The "TREBLE CUT" and "NORMAL" positions are used for phono operation and for normal AM reception where both sidebands are received. In the "NORMAL" position, the audio response is essentially flat at the low- and mid-frequencies and slightly attenuated at the high frequencies. The response in the "TREBLE CUT" position is essentially the same except that the high frequencies are attenuated considerably more than in the "NORMAL" position.

For CW reception, the setting of the RESPONSE control is immaterial although a slight improvement in signal-to-noise ratio will be obtained in the "LOWER SIDEBAND" and "UPPER SIDEBAND" positions.

To illustrate how selectable sideband reception is accomplished in the receiver, a numerical example is given. Consider an incoming signal at 7000 kc, modulated 1 kc. Since modulation of a carrier causes the generation of sideband frequencies numerically equal to the carrier frequency plus or minus the modulation frequency, the incoming signal consists of the carrier at 7000 kc, a lower sideband at 6999 kc, and an upper sideband at 7001 kc. (See Fig. 9A.)

The incoming signal is first heterodyned with the output of the 1st conversion oscillator in the 1st mixer stage. The 1st conversion oscillator operates at a frequency higher than the incoming signal by an amount equal to the first-intermediate frequency of 1650 kc. As a result of the frequency conversion process, three new lower frequencies are produced in the output of the 1st mixer: the carrier at 1650 kc, the lower sideband at 1651 kc, and the upper sideband at 1649 kc. (See Fig. 9B.) These signals are amplified by the 1650 kc IF amplifier stage and then heterodyned with the output of the 2nd conversion oscillator in the 2nd mixer stage.

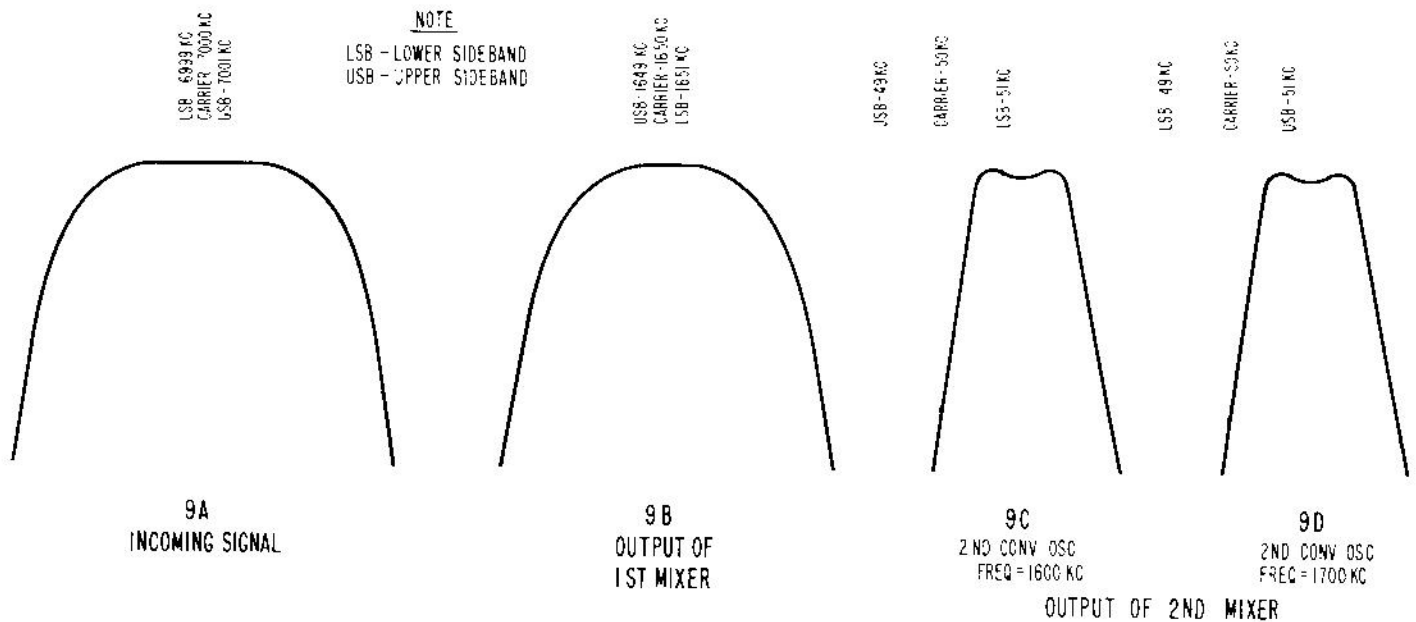

092-402384-C

Figure 9. Selectable-Sideband Response Curves

The 2nd conversion oscillator is crystal controlled and can be set to operate at either 1600 kc for reception of the lower sideband, or 1700 kc for the reception of the upper sideband, selection being made by means of the RESPONSE control. When the RESPONSE control is set at "LOWER SIDE BAND", the 1600-kc signal from the 2nd conversion oscillator is heterodyned with the incoming signal at the first-intermediate frequency of 1650 kc to produce three new frequencies: the carrier at 50 kc, the lower sideband at 51 kc, and the upper sideband at 49 kc. By referring to Fig. 9C, it can be seen that the lower sideband falls within the IF pass-band and the upper sideband falls outside of the pass-band. Thus the lower sideband is accepted and the upper sideband is rejected. When the RESPONSE control is set at "UPPER SIDE BAND", the 1700 kc signal from the 2nd conversion oscillator is heterodyned with the incoming signal. In the frequency conversion process, the carrier still remains at 50 kc, but now the upper sideband appears at 51 kc, and the lower sideband appears at 49 kc. (See Fig. 9D.) Thus, the upper sideband is accepted and the lower sideband is rejected.

Under conditions of crowded amateur bands, the sideband which is most affected by other interfering signals can be rejected, thereby greatly eliminating much of the interference or "QRM". When receiving an AM signal from an amateur station, it is possible to change sidebands during the course of reception, in order to offset changing "QRM" conditions due to adjacent signals disappearing and reappearing within the band.

3-13. "CALIB.-OFF" SWITCH

The CALIB. -OFF switch controls the operation of the built-in 100-kc crystal calibrator. When the switch is set at "CALIB.", the crystal calibrator is turned on to provide marker signals at every 100-kc point on the receiver. The crystal calibrator employs a crystal controlled, pentode oscillator circuit. The output of the crystal calibrator is capacitively coupled to the antenna input circuit. A trimmer capacitor, adjustable

by the CRYSTAL ADJ control on the top of the calibrator unit, permits adjustment of the calibrating crystal to exactly 100 kc by comparison with the 10-mc signal (band 7, WWV 10 MC) transmitted by WWV. This capacitor has been set at the factory and should normally not require periodic readjustment unless extreme calibration accuracy is required. If adjustment is required, proceed as outlined in Section 4-8.

3-14. RECEIVE-STANDBY SWITCH

The RECEIVE - STANDBY switch, when set at "STANDBY", permits disabling of the receiver during transmission periods, at the same time maintaining the heater and plate supplies operative for instant use when reception is again resumed. The receiver operates normally when the RECEIVE-STANDBY switch is at "RECEIVE".

One section of the RECEIVE-STANDBY switch is available for relay or transmitter switching. For connections and details, refer to Section 2-8.

3-15. TUNING CONTROL

The tuning control is used to tune the desired signals within the selected amateur band. The vertical pointer on the slide-rule dial is operated by this control. The dial has six calibrated and individually illuminated scales, one for each of the 160, 80, 40, 20, 15 and 10-11 meter amateur bands covered by the receiver. A seventh band, which uses the dial area covering the 10-11 meter band scale, is purposeful for zero-beating the 10-mc WWV signal for intentions of checking and adjusting the 100-kc crystal calibrator. All bands are illuminated in this position.

It should be noted that the large slide rule dial spreads the amateur bands over most of the total length of the calibrated dial. When checked against the 100-kc crystal calibrator, and dial correction made with the

POINTER RESET control, the dial calibration is extremely accurate. This is especially true on the narrower 160, 40, 20 and 15 meter amateur bands. On these bands the receiver has a dial graduation every

5 kilocycles. The dial accuracy is somewhat less on the 80 and 10-11 meter bands, where there is a dial graduation every 10 kc and 50 kc, respectively.

SECTION IV OPERATION

4-1. AM RECEPTION

1. Set the front panel controls to their starting positions as outlined below.

SENSITIVITY.....10 (maximum sensitivity)
 BAND SELECTOR .At the desired amateur band
 VOLUME 0 (minimum volume)
 AVC ON-OFFON
 NOISE LIMITER-OFF OFF
 AM/CW-SSB AM
 SELECTIVITY..... 5 KC
 RESPONSE.....POWER OFF
 RECEIVE-STANDBY RECEIVE
 NOTCH DEPTH..... OFF
 CALIB. -OFF..... OFF
 POINTER RESET As adjusted
 ANT. TRIMMER..... As adjusted
 PITCH CONTROL..... As adjusted
 NOTCH FREQ..... As adjusted

2. Turn the receiver on by rotating the RESPONSE control clockwise and set it at either the "NORMAL" or "TREBLE CUT" position. The tuning dial and "S" meter will light up indicating the receiver is operative, and the amateur band selected by the "BAND SELECTOR" will be the only band on the slide rule dial illuminated. Rotate the VOLUME control clockwise for the desired volume level.
3. Tune in an AM signal with the tuning control, tuning for maximum indication on the "S" meter. Adjust the ANT. TRIMMER control for maximum indication on the "S" meter. After the signal has been accurately tuned in, readjust the VOLUME control as desired.

NOTE

The "S" meter indications will be correct only when the AVC switch is set at ON, and the SENSITIVITY control is set at 10 (maximum sensitivity). Setting the SENSITIVITY control at a setting other than "10" will also somewhat restrict AVC action.

4. Set the SELECTIVITY control for the desired degree of selectivity. For AM reception, the control can be set to 5 KC for maximum fidelity. The positions marked 3 KC, 2 KC, 1 KC, .5 KC provide progressively increasing steps of selectivity. Note that as the selectivity of the receiver is increased, the background noise and

interference from adjacent signals is reduced. Too much selectivity, however, may cause excessive sideband cutting. While sideband cutting reduces fidelity, it may be frequently preferable to sacrifice naturalness of reproduction in favor of communications effectiveness. When changing the position of the SELECTIVITY control from a broad to a narrower response (for example: from "2 KC" to "1 KC"), a slight readjustment of the tuning controls may be necessary to recenter the signal in the IF passband.

5. Set the RESPONSE control at either "LOWER" or "UPPER SIDEBAND" position.
6. If it is desired to operate with AVC off, set the VOLUME control to a well advanced position, and vary the receiver volume level by means of the SENSITIVITY control, taking care not to advance the control to a point where strong signals will cause "blocking".
7. If severe electrical disturbances, ignition or other types of pulse type noise interfere with reception, set the NOISE LIMITER switch at "ON" to place the automatic noise limiter circuit in operation.
8. The receiver may be disabled without turning it off by setting the RECEIVE-STANDBY switch at "STANDBY". In this position, the RF and 50.5-kc IF stages are cut off but the heater and plate supplies remain operative for instant reception. To resume reception, simply return the switch to the "RECEIVE" position.
9. An undesired signal near the frequency of the desired signal will heterodyne with it to produce an audible beat note equal to their frequency difference. This type of heterodyne interference can be eliminated by using the selectable sideband feature of the receiver to position the undesired signal out of the IF passband. The detailed procedure for eliminating heterodyne interference is as follows:
 - a. Set the AM/CW-SSB switch at "CW-SSB", the PITCH CONTROL to "O", and the RESPONSE control at either "LOWER SIDEBAND" or "UPPER SIDEBAND".
 - b. Carefully tune in the desired signal for "zero beat". Then set the AM/CW-SSB switch at "AM".

- c. If the RESPONSE control has been set to the proper sideband position, the amount of heterodyne interference will be eliminated or minimized. If the interference is still present, simply switch the RESPONSE control to the opposite sideband position.
10. An alternate method of eliminating an interfering signal is to use the notch filter circuit. Simply rotate the NOTCH DEPTH control clockwise to "O" and adjust the NOTCH FREQ control to "notch out" the interfering signal. Readjust the NOTCH DEPTH control as necessary to obtain maximum rejection of the interfering signal.

CAUTION

It is possible to eliminate the heterodyne by notching out the desired carrier in place of the undesired signal or carrier. When this occurs an AM signal will sound like a single sideband suppressed carrier transmission (monkey chatter).

11. In shortwave reception, it frequently happens that transmission conditions are different for waves of slightly different frequencies. As a result, in the case of voice-modulated transmissions, which involve sideband frequencies differing slightly from the carrier frequency, the carrier and sideband components may not be received in the same relative amplitude and phases they had at the transmitter. This effect, known as selective fading, causes severe distortion of the signal. This type of distortion can be reduced somewhat by tuning the receiver to accept only one of the two sidebands being transmitted as previously outlined in steps 9(a) and (b). After tuning is completed, switch the RESPONSE control from "LOWER SIDEBAND" to "UPPER SIDEBAND" and leave it in the position providing the least distortion.

4-2. CW RECEPTION

For CW reception, the receiver may be operated with AVC on or off, as desired. Operation of the receiver with AVC on is highly desirable since it not only minimizes fading but also prevents blasting when tuning from a weak to a strong signal. To operate with AVC on, set the AVC switch at "ON", set the SENSITIVITY control to a well advanced position, and regulate the receiver volume level by means of the VOLUME control. To operate with AVC off, set the AVC switch at "OFF", set the volume control at a well advanced position, and vary the receiver volume level by means of the SENSITIVITY control, taking care not to advance the control to a point where strong signals cause excessive "thumping" (overloading).

CW signals are made audible by the heterodyning action of the beat oscillator with the incoming signal. The beat oscillator is set at a frequency slightly different from the second-intermediate frequency of 50.5 kc, the difference being equal to the pitch of the audible note desired.

For the reception of CW signals, set the AM/CW-SSB switch at "CW-SSB", set the SELECTIVITY control at one of the sharper selectivity positions (2 kc, 1 kc, or .5 kc), set the RESPONSE control at "UPPER SIDEBAND", and set the PITCH CONTROL at any setting from "2" to "4" on either side of zero, and then tune in the signal for a pleasing beat note.

NOTE

Because of the effective band spread of the amateur bands on this receiver, CW signals are easily tuned when the SELECTIVITY control is set at ".5 KC".

The beat oscillator may be set on either the high- or low-frequency side of zero beat. (The oscillator operates on the low side when the PITCH CONTROL is set at a position to the left of zero and on the high side when the PITCH CONTROL is set at a position to the right of zero.) It may be necessary, after setting the PITCH CONTROL, to readjust the receiver tuning slightly to properly position the signal in the IF passband. Alternately adjust the PITCH CONTROL and the receiver tuning for a maximum audible signal. With the receiver in the sharpest selectivity position, CW signals will drop in and out more rapidly and a slower rate of tuning is recommended. Once the PITCH CONTROL has been set, it need not be reset for each CW signal unless a change of pitch is desired.

NOTE

If the SELECTIVITY control is changed to a different position, it may be necessary to readjust the receiver tuning slightly when changing to a narrower selectivity position in order to properly position the signal in the IF passband.

The setting of the SELECTIVITY control for CW reception is generally best determined by receiving conditions. Note that as the selectivity of the receiver is increased (SELECTIVITY control varies from the "5 KC" to the ".5 KC" position), the background noise and adjacent-channel interference is considerably reduced and tuning is sharper. For CW reception, the sharpest selectivity position may be used without the loss of intelligibility experienced in AM reception.

4-3. SINGLE SIDEBAND RECEPTION

Single-sideband signals are transmitted with little or no carrier, and it is necessary to reinsert the carrier in the receiver before proper reception is obtained. In the SX-101 receiver, this is accomplished in the 50.5 kc IF system by injecting the beat oscillator signal at the input of the second-detector. A single-sideband signal (SSB) can be identified by its unintelligibility, or monkey chatter, and by severe variation in the "S" meter indication corresponding to the speech modulation.

For the reception of single-sideband signals, set the PITCH control at "O", AVC switch at "ON", AM/CW-SSB switch at "CW-SSB", and SELECTIVITY control at either "2 KC" or "3 KC", depending upon adjacent

channel interference and noise. Set the SENSITIVITY control at a well advanced position clockwise and vary the receiver volume level by means of the VOLUME control, taking care not to advance the SENSITIVITY control to a point where strong signals will cause distortion (overloading). Set the RESPONSE control at either "LOWER SIDEBAND" or "UPPER SIDEBAND". The single-sideband signal will be intelligible in only one of these two positions, the proper position depending upon the sideband being transmitted. If the signal is not intelligible after tuning is completed as outlined below, set the RESPONSE control to the other sideband setting and repeat the tuning procedure. It is suggested that the RESPONSE control be initially set at "LOWER SIDEBAND" since most single-sideband transmissions are of this type.

After the controls have been properly set as outlined in the preceding paragraph, very carefully tune in the single-sideband signal for maximum intelligibility. It will be noticed that with incorrect tuning of a single-sideband signal, the speech will sound high- or low-pitched or very distorted but no trouble should be encountered in tuning once a little experience has been gained.

The "1 KC" position of the SELECTIVITY control permits reception of modulation frequencies up to about 1000 cycles. For reception of modulating frequencies higher than 1000 cycles, set the SELECTIVITY control to the positions marked "2 KC", "3 KC" and "5 KC", depending on the degree of fidelity desired; maximum fidelity is obtained in the "5 KC" position. Unlike CW on AM reception, it is not necessary to retune the receiver slightly when receiver selectivity is varied. The notch filter is especially useful during reception of single-sideband signals. An undesired AM or CW signal close in frequency to the desired signal will heterodyne with the beat oscillator to produce an audible beat. The undesired signal may be "notched out" with the notch filter, just as in AM or CW reception.

4-4. USE OF CRYSTAL CALIBRATOR

The built-in 100-kc crystal calibrator permits accurate checking of dial calibration on every band by a comparison of the dial calibrations with the marker signals which appear at every multiple of 100 kc on the dial.

A. CALIBRATION OF THE DIAL

1. Set the tuning dial at a convenient multiple of 100 kc at the high frequency end of the amateur band in use (or nearest any particular frequency within the band it is desired to tune). Examples of high frequency end check are: 2000 kc on 160 meters, 4000 kc on 80 meters, 7300 kc on 40 meters, 14,400 kc on 20 meters, 21,500 kc on 15 meters, and 29,700 kc on 10 meters.
2. Set the AM/CW-SSB switch at "CW-SSB", the PITCH control at "O", and the CALIB.-OFF switch at "CALIB."
3. Very carefully adjust the tuning control for the exact 100-kc frequency mark as indicated by "zero beat". If the vertical pointer on the dial does not fall exactly on this 100-kc mark, adjust the POINTER RESET control until the pointer

falls right on the mark. For example, on the 80 meter amateur band, a "zero beat" should be obtained at 3500, 3600, 3700, 3800, 3900, and 4000 kc.

4. The procedure outlined in steps 1 through 3 above provides average calibration accuracy over the entire frequency range of the band in use. For precise calibration accuracy over a particular section of the amateur band, the procedure is identical except that the dial is set at a multiple of 100 kc nearest the desired frequency or range of frequencies, instead of at the high end of the band as in step 1.

4-5. USE OF "S" METER

The "S" meter provides a visual means of determining whether or not the receiver is properly tuned, as well as an indication of the relative signal strength. The "S" meter circuit consists of a DC milliammeter connected in the cathode circuit of the "S" meter tube (V-15), the grid of which is controlled by AVC voltage. Since the cathode current of this tube varies with the strength of the incoming signal, the meter will indicate relative signal strength. The "S" meter is calibrated in microvolts, and also in "S" units from 1 to 9, and in decibels above S-9 to +80 db. The indications on the "S" meter will be correct only when the SENSITIVITY control is set at "10" (maximum sensitivity), and the AVC switch is set at "ON".

NOTE

The "S" meter will also indicate relative signal strength when the AVC switch is at OFF, and/or when the SENSITIVITY control is not fully clockwise.

The limitations of the microvolt scale should be fully understood before any assumption as to the indicated signal voltages is accepted. The meter indicates approximate microvolts of signal strength as developed at the antenna input terminals when terminated in a 50-70 ohm load, at 14.3 mc. This approximation will have a variation on a new receiver and, obviously, as the tubes age the variations may be greater. The indicated microvolt readings at other frequencies will vary approximately from that at 14.3 mc. Also, all readings 50 microvolts or less will be more accurate and correlate more closely than those higher.

Variations in the microvolt indications between receivers is not indicative of the overall sensitivity but is caused by normal tolerances in vacuum tube conductances which are reflected as variations in the AVC/"S" Meter curve. Thus, two receivers with identical sensitivities could, under the same signal conditions indicate signal levels of 5 microvolts and 25 microvolts and yet each be a perfect receiver.

4-6. BFO FREQUENCY CHECK

The beat frequency oscillator (BFO) has been carefully adjusted at the factory so that its frequency is 50.0 kc when the PITCH CONTROL knob is set at "O". Readjustment of the BFO will normally not be required unless the 6SC7 BFO tube (1/2 of V-8) or components in the BFO circuit have been replaced. A slight readjustment sometimes may be necessary occasionally

as a result of normal aging of the BFO tube. A simple check can be made to determine if adjustment is necessary as follows:

With the AM/CW-SSB switch at "CW-SSB", SELECTIVITY control at "5 KC", RESPONSE control at "UPPER SIDEBAND", and PITCH CONTROL at "O", very carefully tune in an AM signal for "zero beat". (See Note A below.) Leaving the receiver tuning unchanged, switch the RESPONSE control to the "LOWER SIDEBAND" position. If the beat oscillator frequency is correct, a "zero beat" will be obtained in both the "UPPER SIDEBAND" and "LOWER SIDEBAND" positions. If, however, the beat oscillator is slightly off frequency, a beat note will be heard when switching from the "UPPER SIDEBAND" to the "LOWER SIDEBAND" position. Adjustment of the beat frequency oscillator is necessary only if the frequency of the audible beat note exceeds 200 cycles.

NOTE A

In instances where the beat oscillator is considerably off frequency, it may not be possible to obtain a "zero beat" when tuning in the signal. In this case, it will be necessary to first "roughly" set the beat oscillator to operate at approximately 50 kc as follows: With the AM/CW-SSB switch at "CW-SSB", SELECTIVITY control at ".5 KC", and RESPONSE control at "UPPER SIDEBAND", tune the receiver to a noisy part of the band (not to a signal). Remove the PITCH CONTROL knob and adjust the BFO slug for minimum noise on the noise signals. Then set the SELECTIVITY control at "5 KC" and make the BFO frequency check as outlined in the preceding paragraph.

If the BFO frequency check indicates adjustment is necessary, proceed as follows:

Remove the PITCH CONTROL knob and turn the BFO slug a few degrees to the left or right so as to lower the beat note frequency, and repeat the BFO frequency check. If the beat note obtained is higher in frequency than that obtained originally, it is an indication that the slug is being turned in the wrong direction. Continue varying the setting of the slug in small steps and repeating the BFO frequency check until "zero beat" is obtained in both the "UPPER SIDEBAND" and "LOWER SIDEBAND" positions. After the correct slug setting is determined, replace the PITCH CONTROL knob with "O" in the top center position, being careful not to disturb the slug setting.

4-7. NOTCH FREQUENCY CHECK

Readjustment of the notch filter circuit is not normally necessary unless the components in the notch filter circuit are replaced. To check the circuit, proceed as follows:

Check the BFO frequency as instructed in Section 4-6. Set the PITCH CONTROL at "O", AVC to "ON" and the SELECTIVITY control at "3 KC". Tune in an unmodulated carrier, from a station, amateur transmitter VFO, or a signal generator, for a "zero beat". Place the AM/CW-SSB switch

in the "AM" position to de-energize the BFO. Rotate the NOTCH DEPTH control to "O". Tune the NOTCH FREQ. for a minimum reading on the "S" meter. The NOTCH FREQ. dial should be set at "50 KC".

If the notch frequency check indicates that an adjustment is necessary, proceed as follows:

Loosen the NOTCH FREQ. knob and reset it to indicate "50 KC". Rotate the control to approximately "51 KC". Tune across an unmodulated carrier while observing the "S" meter. (Use an approximate S-9 signal.) The meter will indicate two peaks. Readjust the NOTCH FREQ. control as necessary to approximately equalize the peaks. Then tune the receiver for a minimum reading on the "S" meter between the two peaks. Adjust the NOTCH ADJ. control R75, located on top of the SX-101 receiver chassis, for a minimum reading on the "S" meter. Refer to Fig. 10 for the location of R75.

4-8. CRYSTAL CALIBRATOR CHECK

The CRYSTAL ADJ. control on the calibrator chassis operates a trimmer capacitor connected across the 100-kc calibrating crystal. This trimmer capacitor permits slight adjustment of the calibrating crystal to exactly 100 kc by comparison with the 10-mc signal transmitted by station WWV. This is done by setting the BAND SELECTOR to "WWV 10 MC" and tuning the receiver to the WWV 10 MC mark on the top scale of the slide rule dial. This capacitor has been set at the factory and should not require periodic readjustment unless extreme calibration accuracy is desired. If adjustment is required, proceed as outlined below.

Set the RESPONSE switch to "NOR", the CALIB.-OFF switch at "OFF", and all other front panel controls as for normal AM reception. Tune in the 10-mc WWV signal and wait for the period during which the signal from WWV is unmodulated. Then switch on the crystal calibrator by setting the CALIB.-OFF switch at CALIB. and adjust its frequency, by means of the CRYSTAL ADJ. control (C105), until the crystal calibrator signal "zero beats" with the signal received from WWV. If the adjustment is attempted during periods that WWV is modulated, an erroneous zero beat may be obtained with the modulating frequency instead of the desired carrier frequency.

4-9. SERVICE OR OPERATING QUESTIONS

For any further information regarding operation or servicing of your SX-101 receiver, contact your Hallicrafters dealer. The Hallicrafters Company maintains an extensive system of Authorized Service Centers where any required service will be performed promptly and efficiently at a nominal charge. All Hallicrafters Authorized Service Centers display the sign shown below.



For the location of the one nearest you, consult your local dealer or telephone directory. Make no service shipments to the factory as The Hallicrafters Company will not accept the responsibility for unauthorized shipments.

The Hallicrafters Company reserves the privilege of making revisions in current production of equipment and assumes no obligation to incorporate these revisions in earlier models.

SECTION V ALIGNMENT

This receiver has been carefully aligned at the factory by specially trained and experienced personnel using precision equipment. Alignment of the receiver should not be attempted until all other possible causes of faulty operation have been investigated. Alignment should not be required unless the receiver has been tampered with or component parts have been replaced in the RF or IF stages. Alignment should be made only by persons familiar with communications receivers and experienced in their alignment. Refer to Figs. 10 and 11 for location of all alignment adjustments.

minals. If a VTVM is used, connect it to terminals "500" and "G" and terminate the output with a 500-ohm resistive dummy load.

5-1. EQUIPMENT REQUIRED

1. Signal generator covering 50 kc to 30 mc.
2. Vacuum tube voltmeter (VTVM) or other high impedance DC voltmeter.
3. Output meter (or AC scale of VTVM). Connect output meter to appropriate speaker output ter-

5-2. INITIAL CONTROL SETTINGS

BAND SELECTOR	As indicated in chart
SENSITIVITY and VOLUME	10 (maximum)
AVC and NOISE LIMITER	Off
AM/CW-SSB	AM
SELECTIVITY	As indicated in chart
RESPONSE	LOWER SIDEBAND
RECEIVE-STANDBY	RECEIVE
Tuning	Gang half meshed
NOTCH DEPTH	Off
ANT. TRIMMER	Mid point
POINTER RESET	Mid point
CALIB. - OFF	Off
PITCH CONTROL	0
NOTCH FREQ	As indicated in chart

CAUTION NOTICE: ALL OSCILLATOR TRIMMER CAPACITORS ARE SOLDERED AFTER ADJUSTMENT, AND ANY READJUSTMENT REQUIRES THE REMOVAL OF THIS "FIXING" SOLDER. FOR RECALIBRATING ADJUST SLUGS ONLY.

5-3. ALIGNMENT PROCEDURE

Step	Signal Generator Connections	Signal Generator Frequency	Band Selector Setting	Output Connections	Selectivity Setting	Remarks
50.5 KC IF ALIGNMENT						
1	High side directly to alignment point "A" (terminal 1 of T2). See Fig. 11. Low side to chassis.	50.5 KC (unmod.)	160 M	VTVMDC probe to alignment point "B" (junction of R48, R49, and C81). See Fig. 11.	.5 KC	Remove 1st conv. oscillator tube V3 from its socket to prevent signal interference. Adjust top slug of T3, T4, T5 and T6 (50.5 KC IF's) for maximum indication, maintaining approx. 1 volt reading on VTVM.
ALIGNMENT OF 1600 KC 2nd CONV. OSC. & 1650 KC IF'S						
2	High side directly to alignment point "C" (pin 7 of V2). Low side to chassis.	1650 KC (mod)	160 M	Output meter across appropriate speaker terminals. (VTVM to alignment point "B" if it is desired to monitor detector voltage.)	5 KC	Replace V3 removed in step 1. Tune generator slowly thru 1650 KC to determine IF passband. Then set generator to center of passband, using sufficient generator output to obtain approx. 1/2 watt receiver output. If no output is obtained, the 1600 KC crystal oscillator may not be oscillating and it will be necessary to turn up the generator output and adjust the 1600 KC crystal activity adjustment (top slug of T9) until output is obtained. Adjust for maximum output by adjusting the signal generator frequency, crystal activity (top slug of T9) and the 1650 KC IF's (top and bottom slugs of T1 and T2). Note that the signal suddenly disappears when the crystal activity slug is turned into the coil and gradually

Step	Signal Generator Connections	Signal Generator Frequency	Band Selector Setting	Output Connections	Selectivity Setting	Remarks
ALIGNMENT OF 1600 KC 2nd CONV. OSC. & 1650 KC IF'S (cont)						
drops in level when the slug is backed out of the coil. Set the crystal activity adjustment (top of slug of T9) for half output on the gentle slope side of maximum response. Then set the generator as near the center of the IF passband as possible and adjust the top and bottom slugs of T1 and T2 for maximum response. Tune through the passband and observe the shape of the response. If it is symmetrical, the adjustment is completed; if not, reset the generator frequency near the center of the passband and repeat T1 and T2.						
ALIGNMENT OF 1700 KC 2nd CONV. OSC.						
3	High side directly to alignment point "C" (pin 7 of V2). Low side to chassis.	1650 KC (mod)	160 M	Output meter across appropriate speaker terminals. (VTVM to alignment point "B" if it is desired to monitor detector voltage.)	5 KC	Set RESPONSE control at "UPPER SIDEBAND". Tune generator slowly thru 1650 KC to determine IF passband. Then set generator to center of passband, using sufficient generator output to obtain approx. 1/2 watt receiver output. If no output is obtained,
the 1700 KC crystal oscillator may not be oscillating and it will be necessary to turn up the generator output and adjust the 1700 KC crystal activity adjustment (bottom of slug of T9) until output is obtained. Adjust for maximum output by adjusting the signal generator frequency and the crystal activity (bottom of slug T9). Note that the signal suddenly disappears when the crystal activity slug is turned into the coil and gradually drops in level when the slug is backed out of the coil. Set the crystal activity adjustment (bottom slug of T9) for half output on the gentle slope side of maximum response.						
IF SENSITIVITY CHECK						
4	With the generator modulated 30% at 400 cycles and connected thru a .05 mfd capacitor to the grid (pin 1) of the 1st mixer tube V2, the IF input required for 1/2 watt receiver output should be approximately 20 microvolts. This assumes the crystal activity is set for half of maximum response as outlined in steps 2 and 3 above.					
RF ALIGNMENT						
<ul style="list-style-type: none"> • Before proceeding with the RF alignment, check the tuning dial for proper indexing. The dial should index with the low frequency end of the bands when the tuning gang is fully closed. • Use an amplitude modulated (30%) signal. • Set SENSITIVITY and VOLUME at "10", AVC and NOISE LIMITER at "OFF", SELECTIVITY at "2 KC", RESPONSE at "LOWER SIDEBAND", and RECEIVE-STANDBY at "RECEIVE". • Connect the output meter across the appropriate speaker terminals. (Connect the VTVM to alignment point "B" if it is desired to monitor the detector voltage.) Maintain a 1/2 watt receiver output. • Connect high side of generator thru 50 to 70-ohm carbon resistor to antenna terminal "A1". Connect jumper between "A2" and "G". • The oscillator frequency is higher than the signal frequency on all bands. 						
Step	Band Selector Setting		Generator & Receiver Frequency		Adjust for Maximum	
5	160 M (Band 1)		2.0 MC		C47 (osc trimmer) C39 (mixer trimmer) C41 (ANT. TRIMMER at mid point)	
	160 M (Band 1)		1.8 MC		L20 (osc. slug) L8 (mixer slug) L1 (ant slug)	
6	80 M (Band 2)		4.0 MC		C48 (osc trimmer) C38 (mixer trimmer) C41 (ANT. TRIMMER at mid point)	

Step	Band Selector Setting	Generator & Receiver Frequency	Adjust for Maximum
R-F ALIGNMENT (cont)			
	80 M (Band 2)	3.5 MC	L21 (osc slug) L9 (mixer slug) L2 (ant slug)
7	40 M (Band 3)	7.3 MC	C49 (osc trimmer) L10 (mixer slug) C41 (ANT. TRIMMER at mid point)
	40 M (Band 3)	7.0 MC	L22 (osc slug) C67 (mixer pad) L3 (ant slug)
8	20 M (Band 4)	14.4 MC	C50 (osc trimmer) L11 (mixer slug) C41 (ANT. TRIMMER at mid point)
	20 M (Band 4)	14.0 MC	L23 (osc slug) C68 (mixer pad) L4 (ant slug)
9	10-11 M (Band 6)	29.7 MC	C52 (osc trimmer) L12 (mixer slug) C41 (ANT. TRIMMER at mid point)
	10-11 M (Band 6)	27.0 MC	L25 (osc slug) C70 (mixer pad) L5 (ant slug)
10	15 M (Band 5)	21.5 MC	C51 (osc trimmer) C10 (mixer trimmer) C41 (ANT. TRIMMER at mid point)
	15 M (Band 5)	21.0 MC	L24 (osc slug) C69 (mixer pad) C2 (ant pad)
11	10 MC WWV (Band 7)	10.0 MC	C53 (osc trimmer) C11 (mixer trimmer) C4 (ant trimmer)

BFO ADJUSTMENT
Refer to Section 4-6.

NOTCH FILTER ADJUSTMENT
Refer to Section 4-7.

"S" METER CALIBRATION
See Section 6-5.

- Make both the mechanical and the electrical "S" meter zero adjustments.
- Connect the signal generator as for RF ALIGNMENT above. Use a 14.3 mc, 50 uv modulated signal.
- Set the receiver controls for AM reception on the 20 M band and accurately tune in the signal.
- Set SENSITIVITY to "10" (maximum), AVC to "ON" and SELECTIVITY to "2 KC".
- Adjust R88 for S9 reading on "S" Meter.

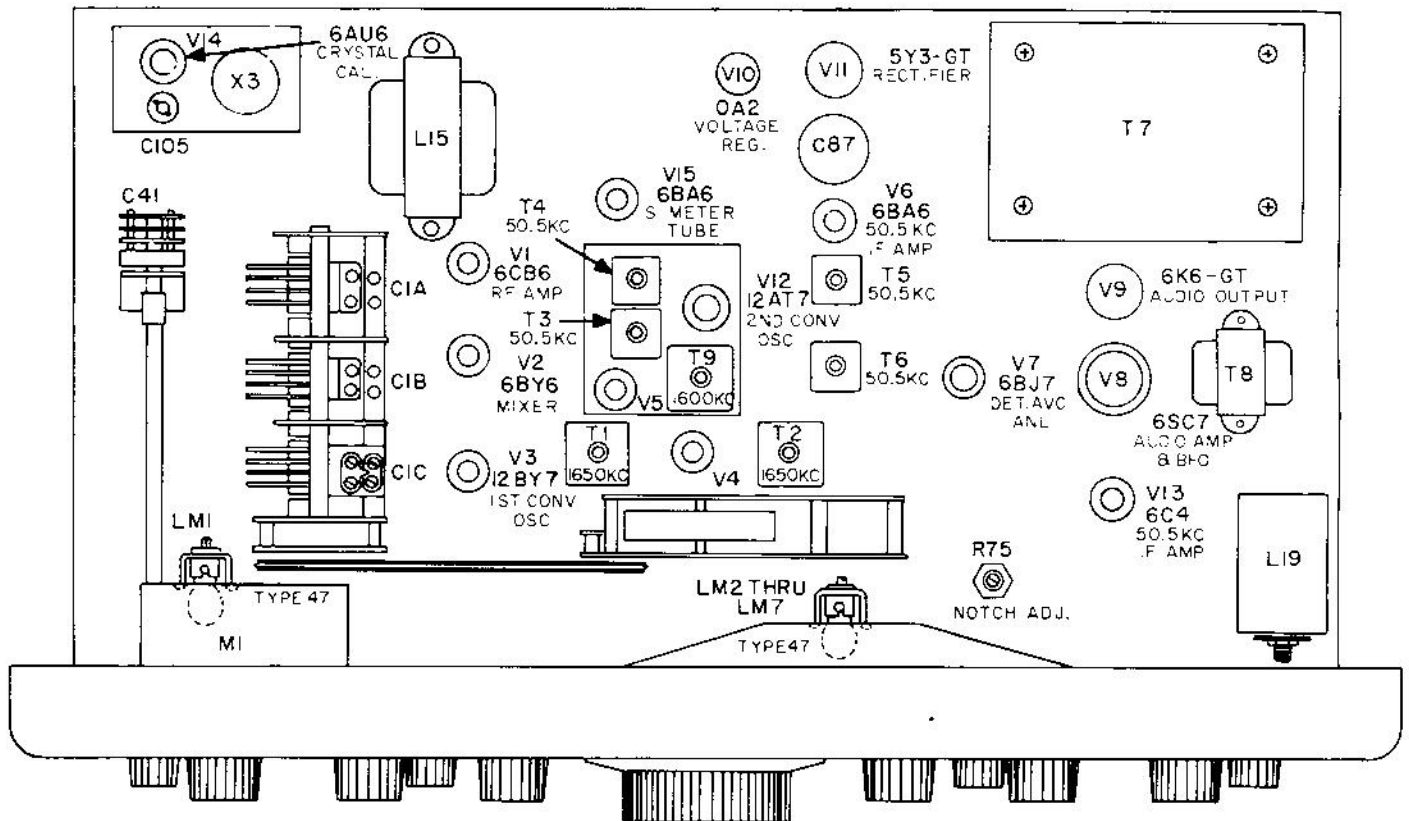

092-205144 - C

Figure 10. Top View of Receiver

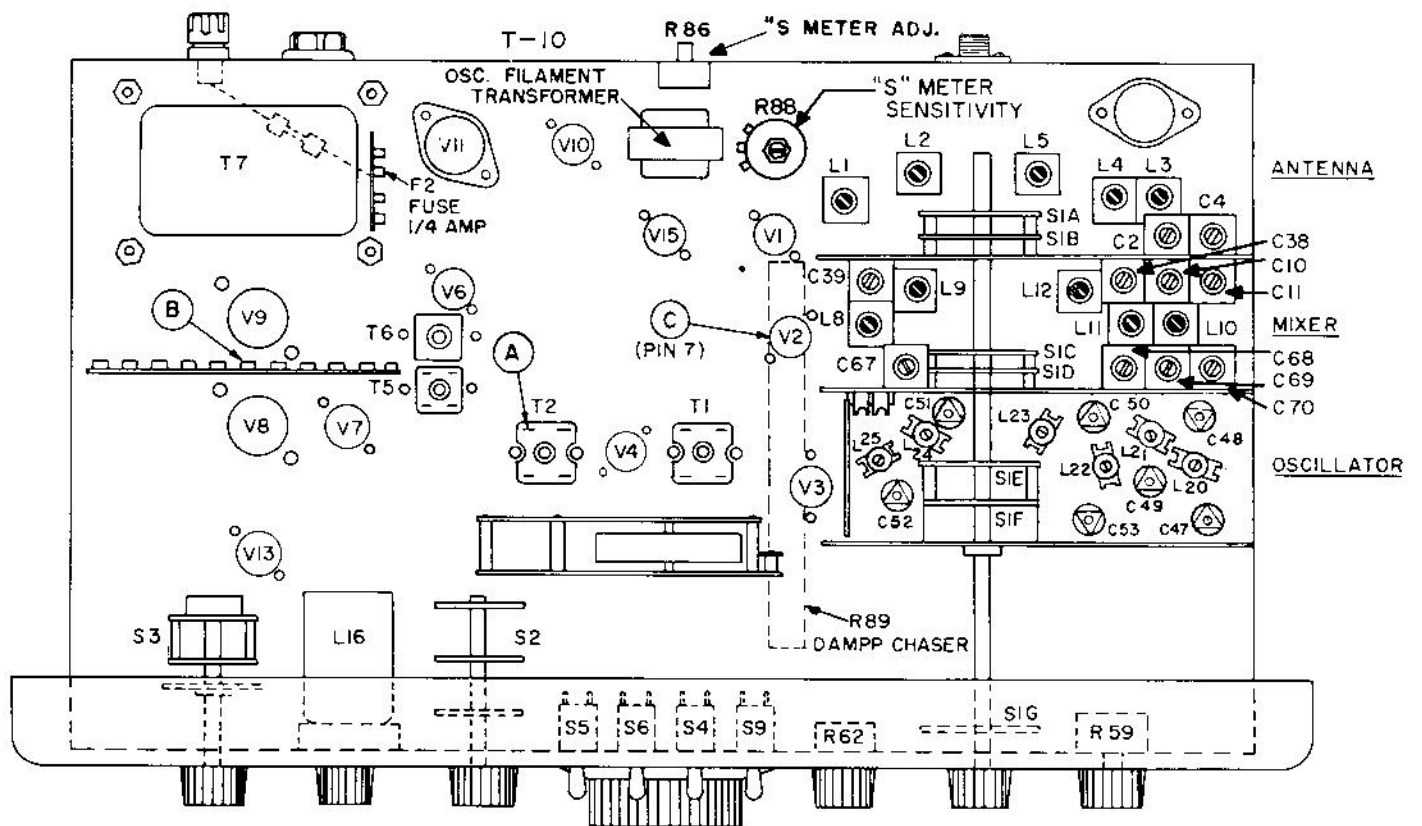

092-205145-D

Figure 11. Bottom View of Receiver

SECTION VI SERVICE DATA

6-1. TECHNICAL SPECIFICATIONS

TUBES..... 13 plus voltage regulator and rectifier
 SPEAKER OUTPUT..... 3.2 and 500 ohms
 HEADPHONE OUTPUT ... 500 ohms (See Section 2-6)
 ANTENNA INPUT..... 50-70 ohms
 PHONO INPUT..... High impedance
 POWER SOURCE..... 105-125 volts, 50/60 cycles

POWER CONSUMPTION 115 watts
 RECEPTION..... AM, CW, and SSB
 INTERMEDIATE FREQUENCIES..... (Double
 Conversion): 50.5 KC and 1650 KC
 DIMENSIONS (overall) 20" wide, 10-1/2" high,
 16" deep
 SHIPPING WEIGHT..... approximately 74 lb.
 NET WEIGHT..... approximately 70 lb.

NOMINAL FREQUENCY COVERAGE			
Band No.	Amateur Band	Calibrated Range	Frequency Between Dial Graduations
1	160 meters	1.8 - 2.0 mc	5 kc
2	80 meters	3.5 - 4.0 mc	10 kc
3	40 meters	7.0 - 7.3 mc	5 kc
4	20 meters	14.0 - 14.4 mc	5 kc
5	15 meters	21.0 - 21.5 mc	5 kc
6	10-11 meters	27.0 - 29.7 mc	50 kc
7	WWV 10 MC		

6-2. 50.5 KC IF SYSTEM

Fig. 12 shows the type of coupling used in the 50.5 kc IF system. Note that inductive coupling is avoided by careful shielding of the IF coils and signal transfer occurs only through capacitance and resistance. By increasing the value of "C" and decreasing "R", the selectivity is made sharper while by decreasing "C" and increasing "R", the selectivity is made broader. The proper values of "C" and "R" are switched in the circuit by means of the SELECTIVITY control. "R" varies the "Q" of the tuned circuit and "C" varies the coupling. This R-C coupling arrangement affords a more accurate means of selectivity control than that readily obtainable by any other method.

6-3. CHASSIS REMOVAL

The chassis and front panel assembly are removable from the cabinet as a unit by removing two screws (Top & Bottom) at each side of the front panel and the three screws on the underside of the cabinet.

6-4. TUBE AND DIAL LAMP REPLACEMENT

To gain access to the tubes and dial lamps, raise the hinged top cover of the cabinet. The tube locations and their functions are shown in Fig. 10.

6-5. "S" METER ADJUSTMENTS

The mechanical adjustment of the "S" meter is accessible at the rear of the meter. The mechanical adjustment has been accurately set at the factory and will normally not require any further adjustment. Adjustment can be made, if required, by turning off the receiver and carefully rotating the adjustment screw until the meter pointer is in line with the right-hand index mark.

The electrical adjustment is made by carefully turning the "S" METER ADJ control R86 on the rear of the receiver chassis (Fig. 11), until the pointer is in line with the left-hand index mark. The electrical adjustment should be made with the receiver on, antenna terminals shorted, SENSITIVITY at "10", AM/CW-SSB switch at "AM", AVC switch at "ON", and RECEIVE-STANDBY switch at "RECEIVE". The settings of the remaining controls do not affect the "S" meter reading.

6-6. DIAL CABLE RESTRINGING

1. Remove the chassis from the cabinet (par. 6-3).
2. Remove the knobs and front panel. This is done by removing four screws from the front panel, and the locknuts from the five toggle switches and the phone jack.

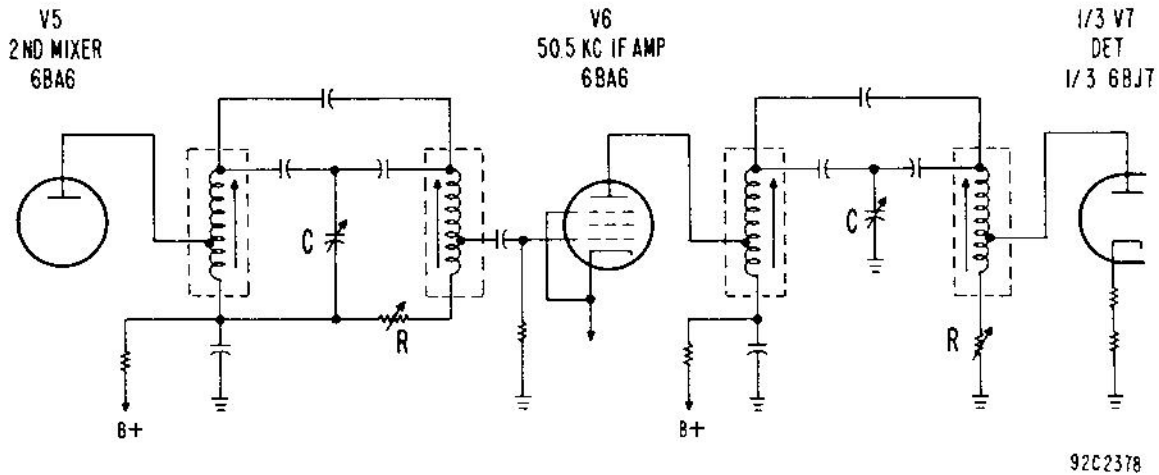

Figure 12. Equivalent Schematic Diagram of 50.5 KC IF System

3. Remove the dial panel assembly by removing two screws, nuts and lockwashers at each side of the chassis. Carefully lift the dial panel assembly upward and lay it on the chassis; take care not to damage the gears or IF cans and slugs.
4. Turn the tuning shaft fully counterclockwise so that the tuning gang capacitor is fully meshed.
5. Restraining the dial cord as follows (Fig 13):
 - a. Attach the end of the cord to the tab (1) and pull the cord down and around the wheel (2 and 3) down behind wheel A (4).
 - b. Continue up over wheel B (6) up to wheel C (7). Proceed across pointer rail to wheel D (8).
 - c. Continue around wheel D to the left and over wheel E (9). Proceed down behind wheel F (10).
 - d. Finish up by routing the cord into the wheel slot (11) and attach the spring on the tab (12).
6. Set the POINTER RESET shaft at the halfway point of its travel.
7. Set the pointer on the pointer rail and engage the dial cord. Do not crimp the tabs on the pointer at this time.
8. Temporarily set the dial panel assembly in place to line up the pointer. The tuning shaft should be fully counterclockwise and the tuning gang capacitor fully meshed.
9. Line up the pointer on the left-hand low frequency marks on the dial.
10. Remove the dial panel assembly and crimp the tabs on the pointer. Place a drop of cement on the pointer tabs and dial cord to permanently secure the pointer and dial cord.
11. Rotate the tuning shaft from the low end to the high end, and back to the low end. Do this several times. Check for backlash or jerky motion of the pointer. If this occurs, it may be necessary to shorten and tighten the dial cord, straighten the pointer, or both.
12. Replace the dial panel assembly, front panel, knobs, and return the chassis to the cabinet.

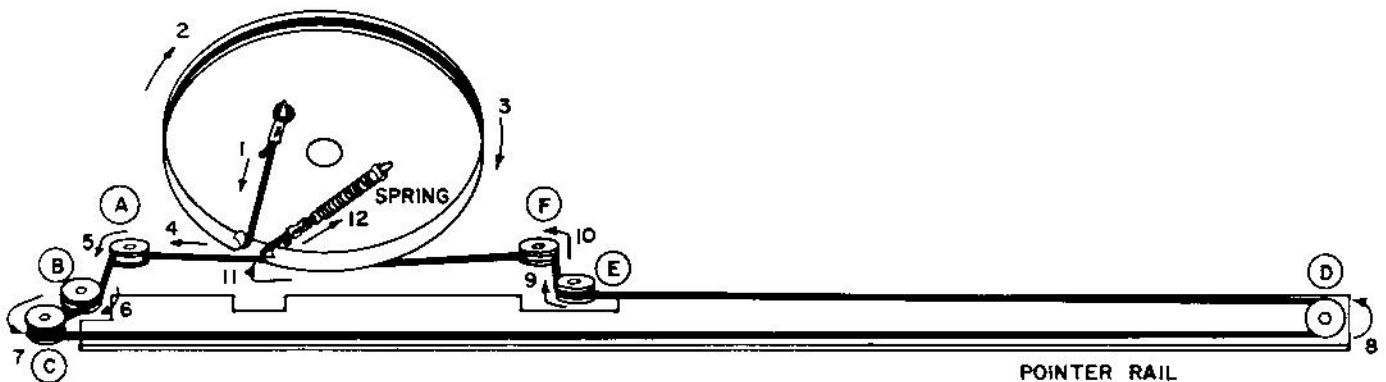

Figure 13. Dial Cord Stringing Diagram

92B2715

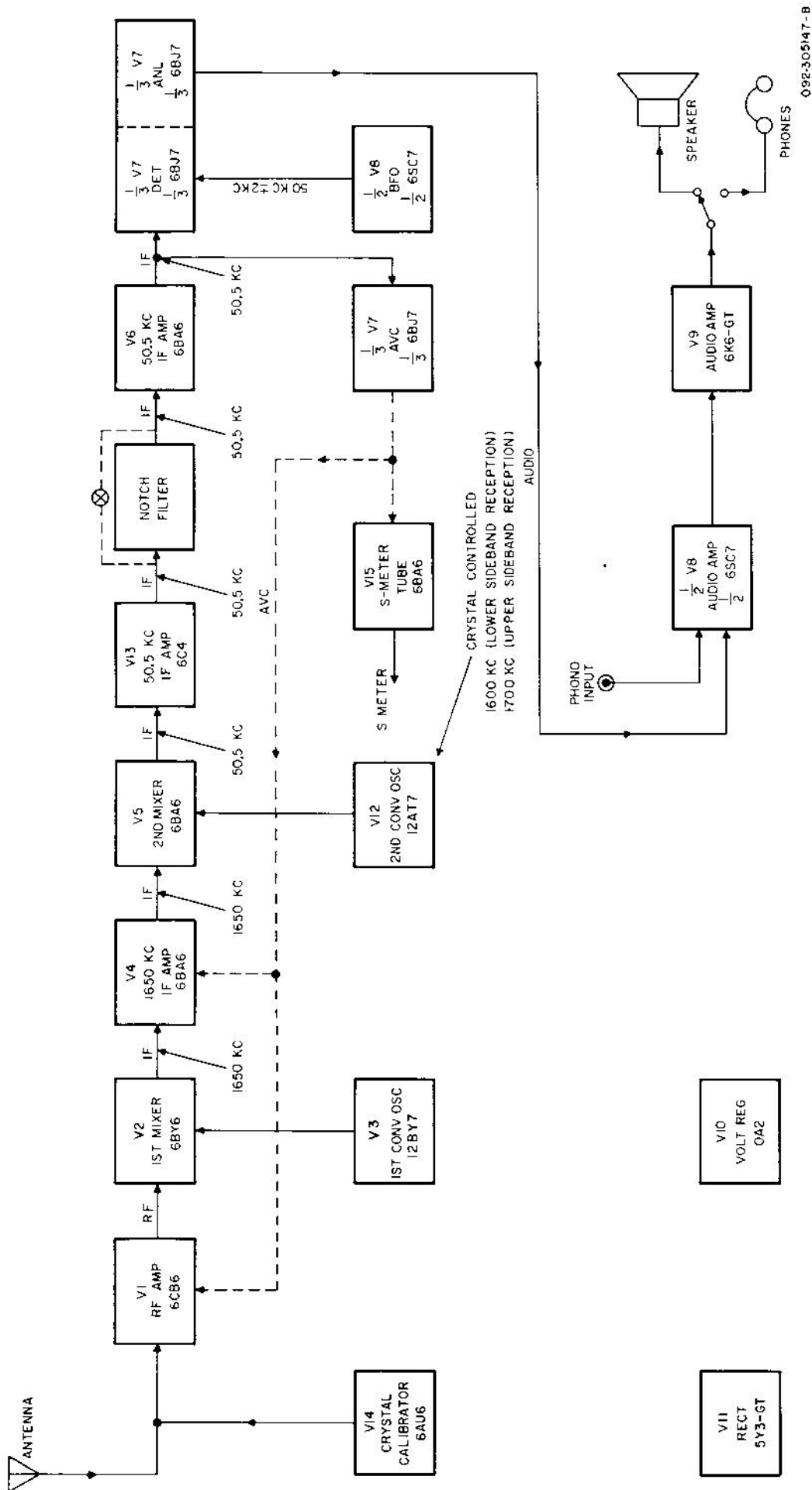
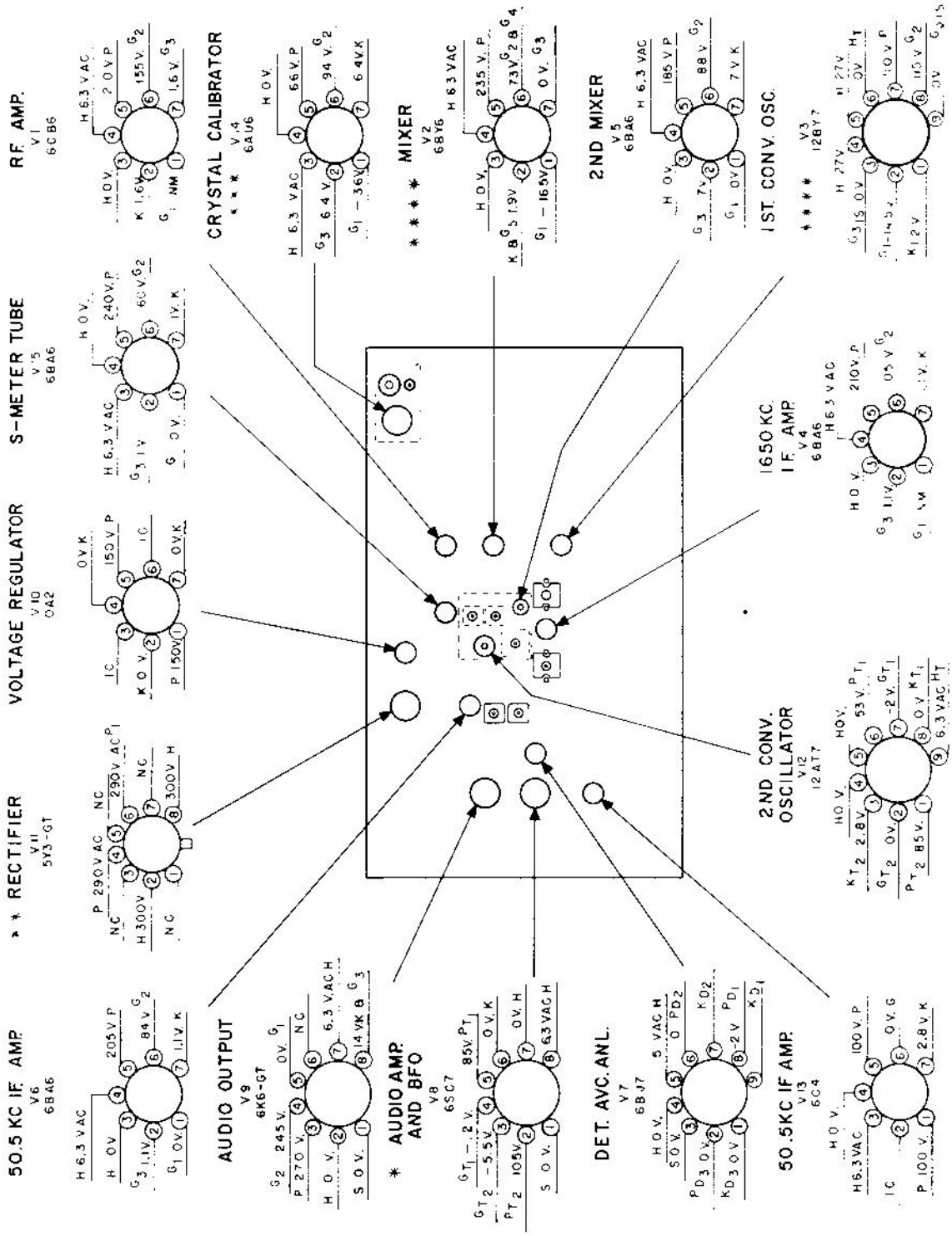

Figure 14. Block Diagram of SX-101 Receiver

092305147-B



- NOTES:
 VOLTAGE READINGS TAKEN UNDER THE FOLLOWING CONDITIONS:
1. LINE VOLTAGE - 117 VOLTS, 60 CYCLES AC.
 2. ANTENNA TERMINALS SHORTED, SENSITIVITY AT "10", RECEIVE-STANDBY AT "RECEIVE", AM/CW-SSB SWITCH AT "AM", AVC AT "ON", NOISE LIMITER AT "OFF", RESPONSE AT "LOWER SIDEBAND", SELECTIVITY AT "5 KC", AND BAND SELECTOR AT "160M".
 3. ALL VOLTAGES ARE DC AND POSITIVE UNLESS OTHERWISE SPECIFIED. DC VOLTAGES MEASURED WITH VTVM, AC VOLTAGES WITH 000 OHMS-PER-VOLT METER.
 4. ALL VOLTAGES MEASURED BETWEEN TUBE SOCKET TERMINALS AND CHASSIS UNLESS OTHERWISE SPECIFIED.
 5. VOLTAGES SHOWN FOR V12 ARE WITH RESPONSE CONTROL AT "LOWER SIDEBAND" IN THE "UPPER SIDEBAND" "TREBLE CUT" AND "NORMAL" POSITIONS, THE VOLTAGES OF THE TWO TRIODE SECTIONS ARE REVERSED. THE GRID VOLTAGE WILL VARY WITH CRYSTAL ACTIVITY.
- * VOLTAGES FOR PINS 2 AND 3 OF V8 ARE TAKEN WITH AM/CW-SSB SWITCH AT "CW-SSB".
 - ** 5 VAC MEASURED ACROSS PINS 2 & 6
 - *** MEASURED IN CALIBRATE POSITION
 - **** VOLTAGE VARIES WITH SETTING OF TUNING GANG AND BAND SWITCH
 - NM NOT MEASURABLE
 - C- INTERNAL CONNECTION
 - NC - NO CONNECTION
 - *T HEATER MID-TAP
 - IS - INTERNAL SHIELD

OSP 402740 B

Figure 15. Voltage Chart.

SERVICE PARTS LIST

Schematic Symbol	Description	Hallcrafters Part Number	Schematic Symbol	Description	Hallcrafters Part Number	Schematic Symbol	Description	Hallcrafters Part Number
CAPACITORS			CAPACITORS (CON'T)			COILS (CON'T.)		
C-1	Tuning	048-400387	*C-140	38 mfd, ±2%, N330; Ceramic	491-004360-73	L-17, 18	Choke, RF	053-400008
C-2, 4	5-80 mmf and 100-450 mmf, dual trimmer; mica compression	044-200479	C-141	.5 mfd, 20%, 400V; molded paper	499-024504	L-19	Coil, T-bridge	051-102270
C-3	20 mmf, 10%, N750; ceramic	491-106200-95	*Some chassis use a 38 mmf, ±2%, N470; ceramic, 491-004360-83 or a 36 mmf, ±2%, N220; ceramic, 491-004360-63 depending on the running characteristics of the receiver.			L-20	Coil, Osc. (Band 1)	051-202335
C-5, 114, 121, 123	51 mmf, 10%, N750 ceramic	491-106910-95	*RESISTORS			L-21	Coil, Osc. (Band 2)	051-202336
C-6, 15	.02 mfd ±80-20%, 17, 22, 500V; cer. disc.	047-100242	R-1, 5,	1 megohm	451-252105	L-22	Coil, Osc. (Bands 3 & 7)	051-202337
24, 25, 26, 125, 128, 134, 135, 136, 137			R-2, 33,			L-23	Coil, Osc. (Band 4)	051-202338
C-7, 14,	.005 mfd ±80-20% 500V; cer. disc.	047-100168	R-2, 41	180 ohms	451-252181	L-24	Coil, Osc. (Band 5)	051-202339
C-8, 33,	.047 mfd, 600V; molded paper	499-034473	R-3, 8,	15K ohms, 2 watt	451-652153	L-25	Coil, Osc. (Band 6)	051-202340
C-9	1500 mmf, 10%, 500V; mica	470-213152	15			L-26	Coil, RF	053-200475
C-10, 11,	5-50, 100-350, 5-50 mmf, triple unit compression; mica	044-100480	R-4, 96	3.9K ohms, 1 watt	451-352392	L-27	Coil, RF (Choke) 2.2 uh 1.1 ohms DC	053-200193
C-12, 115	.005 mfd; ceramic disc.	047-200523	R-6, 63,	220K ohms	451-252224	TRANSFORMERS		
C-13, 90,	.022 mfd, 600V; molded paper	499-034223	80, 90			T-1, 2	Transformer, 1st and 2nd IF (1650 KC)	050-200488
C-18	15 mmf, 10%, N750; ceramic	491-106150-95	R-7	330 ohms	451-252331	T-3, 4,	Transformer, IF (50.5 KC)	050-200489
C-19, 20,	.01 mfd ±80-20%, 500V; cer. disc.	047-100224	R-9, 10	47K ohms, 1 watt	451-352473	T-7	Transformer, Power	052-400474
C-27, 129	100 mmf, 10%; 500V; ceramic	491-026101-94	R-11, 30	3.3K ohms	451-252332	T-8	Transformer, Output	055-100312
C-28, 29,	390 mmf, 5%; 500V; mica	482-262391	R-12, 19	100K ohms	451-252104	T-9	Transformer, 2nd Conversion Oscillator	050-300689
C-30, 36,	2.2 mmf, 10%, 500V; ceramic	047-200403-04	20, 21,			T-10	Transformer, Filament	052-100540
C-31, 96,	470 mmf, 10%, 500V; mica	470-213471	22, 23,			SWITCHES		
C-32, 85	.22 mfd, 20%, 200V; molded paper	499-014224	79, 92			S-1A	Wafer (Antenna Input)	052-200109
C-39	4-80 mmf, mica compression	044-200477	R-13	15 ohms	451-262180	S-1B	Wafer (Antenna Grid)	062-200110
C-41	3-50 mmf, ant. trimmer	048-200313	R-14, 28,	100 ohms	451-252101	S-1C	Wafer (Mixer Grid)	062-200105
C-44	110 mmf, 2%, 500V; mica	482-161111	91			S-1D	Wafer (Mixer Plate)	062-200106
C-46	100 mmf, N75, 2%; ceramic	491-064101-42	R-16, 94	3.3K ohms, 1 watt	451-352332	S-1E	Wafer (Osc. Plate)	062-200120
C-47, 48,	3-30 mmf, Trimmer (Atr)	048-200415	R-24, 85	22K ohms	451-252223	S-1F	Wafer (Osc. Grid)	062-200121
49, 50,			R-25, 70	2.2K ohms	451-252222	S-1G	Wafer (Pilot Light)	062-200111
51, 52,			R-26, 50	120K ohms	451-252124	S-2A, B	Switch, Selectivity	060-200673
53			R-29	39K ohms, 1 watt	451-352393	S-3A, B	Switch, Response	060-200672
C-67	3-30 mmf, mica, compression insulated	044-200478	R-31	8.2K ohms, 1 watt	451-353822	S-4	Switch, SPDT Toggle; AVC	060-100139
C-68, 69,	5-50 mmf, each section mica; compression insulated	044-100475	R-34, 95	10K ohms, 1 watt	451-352103	S-5, 6,	Switch, SPST Toggle; AM/CW-SSB, Noise Limiter and CALIB-OFF	060-100138
C-73, 82	4700 mmf, 10%; 600V; molded paper	499-031472	R-37	2.5K ohms, 10 watt, ww	453-062252	9		
C-74, 83	.01 mfd, 10%, 600V; molded paper	499-031103	R-38	820 ohms	451-252821	S-7A, B	Switch, DPST Toggle; Receiver-Standby	060-100192
C-75, 84,	.022 mfd, 10%, 600V; molded paper	499-031223	R-39	470 ohms	451-252471	S-8	Part of H76	-----
C-76	.001 mfd, 20%; 500V; ceramic	047-100503	R-40, 67	470K ohms	451-252474	JACKS, PLUGS AND SOCKETS		
C-78, 79,	220 mmf, 5%; ceramic	478-026221	R-42, 57	220 ohms	451-252221	PL-1	Line Cord and Plug	087-104690
C-87A,	60-20-20 mfd, 450V,		R-43, 58	390 ohms	451-252391	PL-2	Plug, Octal; Jumper Socket, Tube; Min 7-Pin (J) Lock	035-100003-01
B, C	450V, 400V; electrolytic	045-200113	R-46	47 ohms, 1 watt	451-352470		Socket, Tube; Min. 9-Pin (J) Lock	006-200672
C-93	330 mmf, 10%, 500V; 120a	470-223301	R-47	10K ohms, 5%, 2 watt	451-651103	SO-1	Jack, Phone	036-100041
C-94	560 mmf, 5%, 500V; mica	470-232561	R-49	820K ohms	451-252824	SO-2	Socket, Tube; Octal Jack, Phone	006-200026
C-95	10 mmf, N4700; cer.	479-042100	R-51, 52	5.8 ohms	451-252068	SO-3	Socket, Tube; Min. 7-Pin	006-100759
C-97, 98,	.001 mfd, 20%, 500V; molded paper	499-034102	R-53	270K ohms	451-252274	SO-5	Connector, Coax	010-100056
C-100	10 mfd, 50V; electrolytic	045-100211	R-54, 65,	47K ohms	451-252473	TUBES AND LAMPS		
C-103,	7500 mmf, 5%, 500V; mica	470-422752	66, 93			V-1	6CB6; RF Amplifier	090-901115
C-105	8-50 mmf, trimmer, N750	044-200437	R-59	10K ohms, 2 watt, Variable Sensitivity	025-201574	V-2	6BY6; Mixer	090-901114
C-107	82 mmf, 10%, 500V; mica	470-213820	R-60	330K ohms	451-252334	V-3	12BY7; 1st Conv. Osc.	090-900041
C-110,	.01 mfd, GMV, 1400 W, V, D, C. (AC Line By-Pass)	047-200752	R-61, 97	10K ohms	451-252103	V-4, 5,	6BA6; 1650 KC IF Amplifier; 2nd Mixer, 50.5 KC IF Amplifier; and "S" Meter Tube	090-901112
C-122	82 mmf, N750, 10%; ceramic	491-026820-94	R-62	500K ohms, Variable Volume	025-200534	6, 15	6B7; Detector, AVC, and Noise Limiter	090-901113
C-132	.1 mfd 20%, 600V; molded paper	499-034104	R-64	15 megohms	451-262156	V-7	6SCT; Audio Amplifier & BFO	090-900874
C-138	330 mmf ±2%; Dura Mica	482-161331	R-68	390 ohms, 1 watt	451-352391	V-9	6K6GT; Audio Output	090-900856
C-139	24 mmf ±5%; Dura Mica	482-162240	R-69	360 ohms, 1 watt	451-353561	V-10	0A2; Voltage Regulator	090-900001
			R-72	12K ohms	451-252123	V-11	5Y3GT; Rectifier	090-901111
			R-74	1K ohm	451-252102	V-12	12AT7; 2nd Conversion Osc.	090-900034
			R-75	15K ohms, Variable Notch Adj.	025-201231	V-13	6C4; 1st Conversion Osc. 50.5 KC IF Amplifier	090-900830
			R-76	5K ohms, Variable w/switch Notch Depth	025-101480	V-14	6AU6; Crystal Calibrator	090-900808
			R-77	680K ohms	451-252684	LM-1 thru 7	Light, Pilot, Type #47	039-100004
			R-78	4.7K ohms	451-252472	KNOB AND KNOB SKIRTS ASSEMBLY		
			R-86	200 ohms, Variable "S" meter adj.	025-200714	Knob, Pitch Control	015-101195
			R-88	2 megohms	025-201052	Knob, Volume or Sensitivity	015-101194
			R-89	Heater, 8 watts, 117V, A, C.	021-200337	Knob, Selectivity	015-101196
						Knob, Response	015-001198
						Knob, Notch Freq.	041-150096
						Knob, Notch Depth	041-150097
						Knob, Band Selector	015-101197
						Knob, Pointer Reset	015-101206

SERVICE PARTS LIST (Cont)

Schematic Symbol	Description	Halterafters Part Number	Schematic Symbol	Description	Halterafters Part Number	Schematic Symbol	Description	Halterafters Part Number
KNOB AND KNOB SKIRTS ASSEMBLIES (CONT.)			MISCELLANEOUS (CONT.)			MISCELLANEOUS (CONT.)		
.....	Knob, Ara. Trimmer	015-101208	X-1, 2	Matched Crystal Pair, Consists of One 1600 KC Crystal and one 1700 KC Crystal	019-201902	Rubber Channel, Escutcheon	016-100755
.....	Knob, Tuning, Logging	015-101207	Escutcheon, Front Panel	007-400664	M-1	"S" Meter	082-300323
MISCELLANEOUS			Foot, Mtg. Flywheel	016-100029	Screw, Set (1/4-32 x 2 1/4") Slit. Hd.)	003-101712
.....	Ball Bearing (1 8" Dia.)	077-100505	Fuse, 2 amp. Slo-Blo	039-100428	Screw, Set (1/8-32 x 3 1/2" Bristol Hd.)	003-101714
.....	Ball Bearing (.003" Dia.)	077-101099	Fuse, 1.4 Amp. W Leads	039-100338	Screw, Set (1/8-32 x 3 1/2" Bristol Hd.)	003-103178
.....	Ball Race	077-201020	Fuse Holder (T-1)	006-100451	Screw, Set (1/8-32 x 3 1/2" Bristol Hd.)	003-103182
.....	Bracket, Dial Scale Mtg.	067-104283	Gear, Drive (Idler)	026-200258	Screw, Set (1/8-32 x 1 1/4")	003-103177
.....	Bracket, Diffuser Mtg.	067-104296	Gear (99 Tooth, 48 Pitch) Fixed	026-200514	Screw, Set (1/8-32 x 1 1/4" Hex Hd.)	003-103547
.....	Bracket, Rear Antenna Trimmer	067-104293	Gear (99 Tooth, 48 Pitch) Loose	026-200515	Separator, Light Diffuser	032-300713
.....	Bracket, Front Antenna Trimmer	067-104294	Gear (55 Tooth, 48 Pitch)	026-200516	Shaft, Gear	074-201271
.....	Bracket, Gear Adj. (Second Plate Gear)	067-103042	Glass, Dial Scale (Calibrated)	022-400579	Shaft, Bandswitch	074-201276
.....	Bracket, Gear Adj.	067-204315	Grommet, Meter	016-100200	Shaft, Purior Dial	074-201270
.....	Bracket, Gear Drive Mtg.	067-103011	Index Plate	063-202384	Shaft, Rail Adj.	074-201269
.....	Bracket, Left Hand Chassis Support	067-404127	Insulator, Bakelite: .156" ID, .05" OD, 1 4" Th.	008-100723	Shaft, Variable Shield, Cover	069-200843
.....	Bracket, Right Hand Chassis Support	067-404128	Light Diffuser	069-300954	Shield, Switch Assembly Mtg.	069-100953
.....	Bracket, Rail Pointer Assembly	067-205594	Lock, Line Cord (Male)	076-100953-01	Shield, Light	069-400951
.....	Bracket, Pot. Mtg.	067-104280	Lock, Line Cord (Female)	076-100953-02	Shield, Tube (7 Pin)	069-100097
.....	Bracket, Rail Adj.	067-204296	Medallion "a"	007-100688	Shield, Tube (9-Pin, 12BY7)	069-000663
.....	Bracket, Rail Mtg.	067-204290	Pad, Brake (Flywheel)	008-102366	Spring, Anti-backlash	075-100231
.....	Bracket, "S" Meter Adj.	067-104204	Panel, Front	068-400528	Spring, Compression	075-100322
.....	Bracket, Gear (Left Mtg. Assembly)	067-203092	Pilot Light Assembly (Meter)	086-200255	Spring, Dial Wire	075-100570
.....	Bracket, Shield (Bandswitch)	067-204314	Pilot Light Assembly (Dial)	086-200256	Spring, Flywheel	075-100345
.....	Bracket, Stop	067-104281	Plate, Gear (First)	063-202362	Spring, Idler Follower	075-200610
.....	Bracket, Stop Arm	067-104306	Plate, Gear (Second)	063-303237	Spring, Rail Hold Down	074-100816
.....	Bracket, Trimmer	067-204309	Plate, Gear (Third)	063-302364	Stop Arm Assembly	074-201280
.....	Bushing, BFO Stop	077-101023	Plate, Gear (Front Gang Mtg.)	063-202366	Trimount Stud	065-100096
.....	Bushing, Pointer Rail	077-200495	Plate, Gear (Rear Gang Mtg.)	063-202367	Washer, Finishing (1 4" ID x 3 1/2" OD x 3 32" Th.)	004-100268
.....	Bushing, Stop	077-101346	Plate, Pointer Adj.	063-202365	Washer, Spring Steel (1 4" ID x 1 2" OD x .010 Th.)	004-100490
.....	Cabinet Assembly	066-401446	TS-1	Pointer	082-300322	Washer, Flat (.130" ID x 1.2" OD x .031 Th.)	004-101675
.....	Cabinet, Top	066-101444	TS-2	Post, Binding (Antenna)	088-100032	Washer, Flat (.127" ID x 3 8" OD x .031" Th.)	004-101741
.....	Cam Assembly (Main Tuning)	077-200914	Post, Binding (Speaker)	088-100578	Washer, Lock (1/8 Ext.)	426-002643
.....	Cap, Glass Mtg.	076-101815	Post Latch	011-100226	Washer, Lock (1/6 Int.)	426-001543
.....	Collar, Switch Shaft	077-100043	Pulley, Idler	028-200260	Window, Escutcheon	022-300537
.....	Connector, Dial Wire	076-102084	Pulley, Gear and Bushing Assembly	041-350140	Xtal Assembly	001-902508
.....	Core, Iron IF and RF	077-100068	Roll Pin (3 8" Long)	074-100738		
.....	Core, Iron, RF Osc.	003-101543	Roll Pin (7 16" Long)	074-101034		
.....	Coupler, Flexible	029-100294	Roll Pin, Tuning and Bandspread Hub	074-100619		
.....	Coupler, Solid	029-100264		
.....	Cover, Transformer	066-200976		
.....	Cover, Bottom	063-201752		
.....	Cover, Drive Assembly	066-301428		
.....	Cover, Gang Mtg.	066-301429		
X-3	Crystal Marker, 100 KC	013-101915		
.....	Dial, Cable	034-100034		

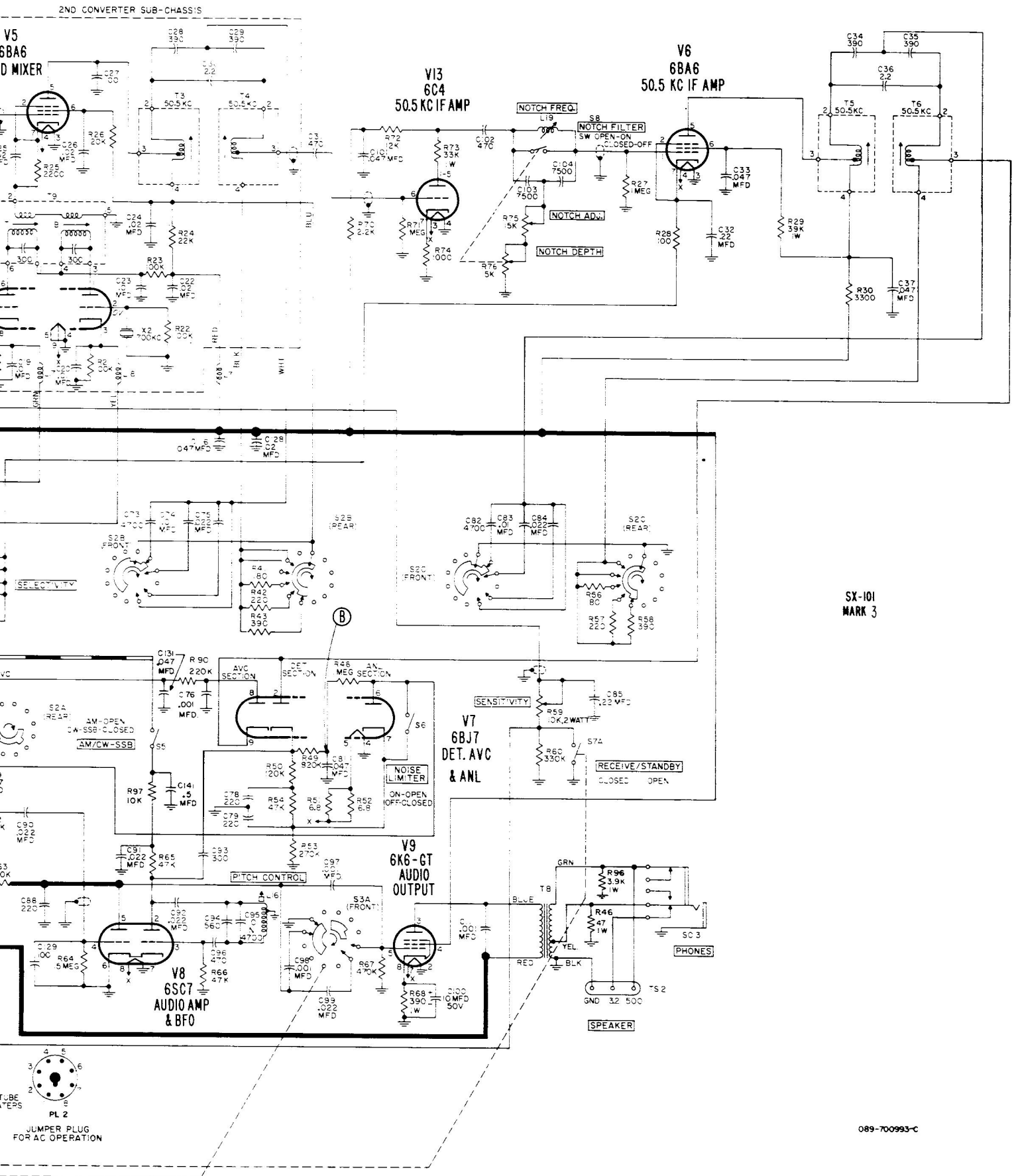

LAST "C" SYMBOL C141
 LAST "R" SYMBOL R97

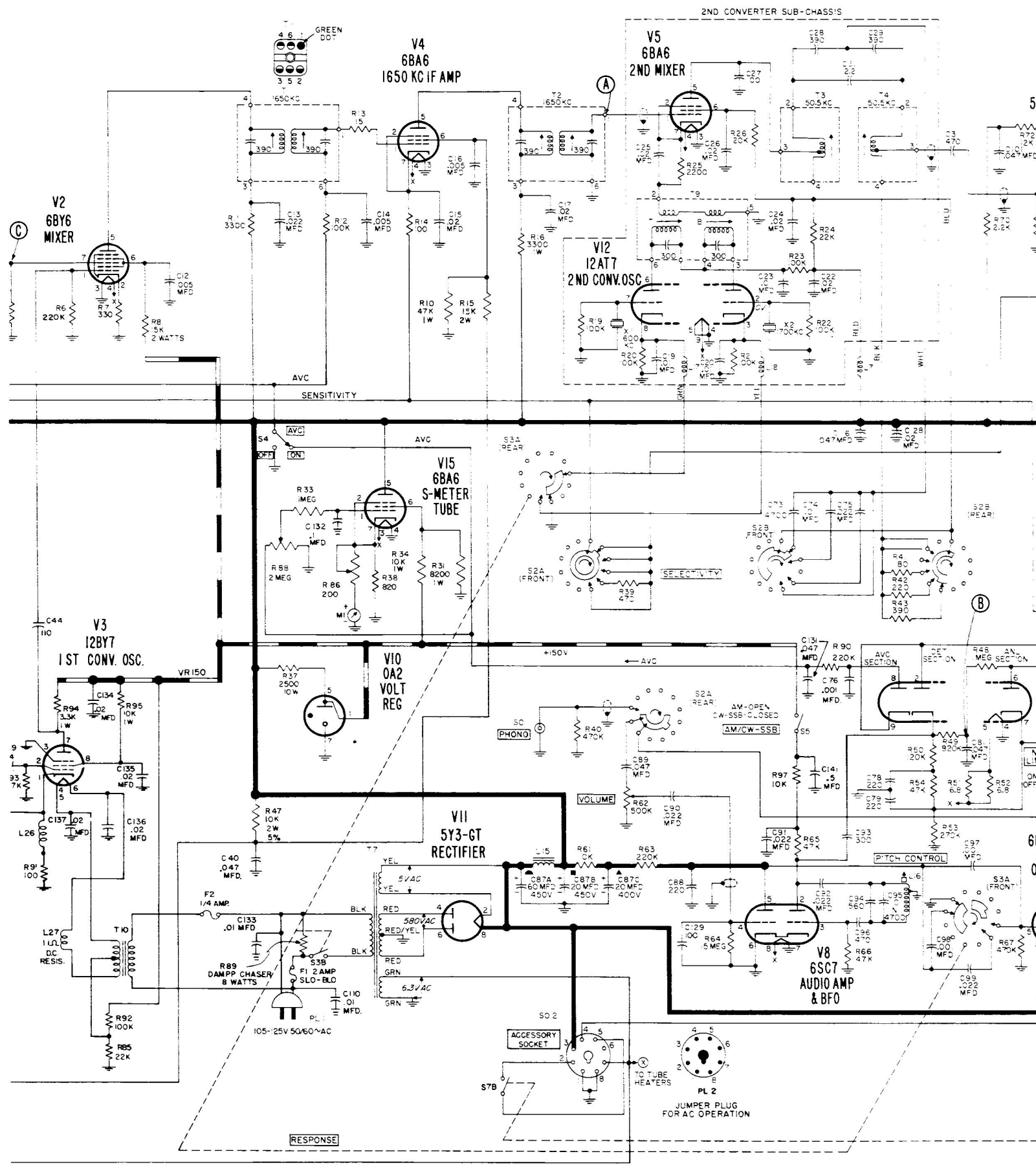

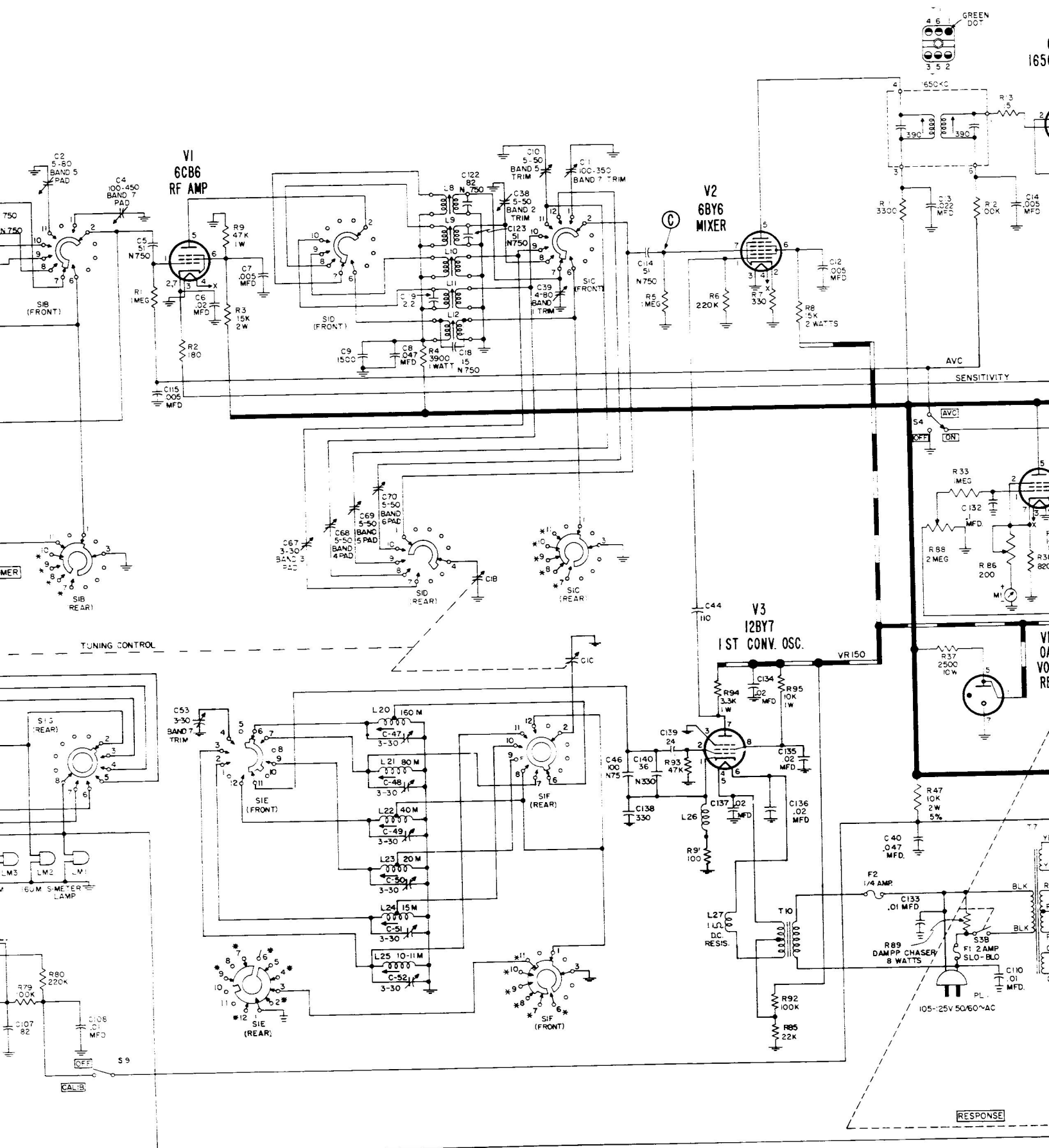

V1
6CB6
RF AMP

V2
6BY6
MIXER

V3
12BY7
1ST CONV. OSC.

TUNING CONTROL

SENSITIVITY

RESPONSE

OL C141
OL R97

NOTES

1. Resistor values in ohms and capacitor values in MMF unless otherwise specified. K = 1000.
2. Resistors are 1/2 watt and 10% unless otherwise specified.
3. Band Selector switch S1 shown in "160 M" position (fully counterclockwise). Switch sections are shown as viewed from front of set.
4. Selectivity switch S2 shown in "5 KC" position (fully counterclockwise). Switch sections are shown as viewed from front of set.
5. Response switch S3 shown in "Lower Sideband" position. Section S3B is open in the "Power Off" position and closed in all other positions.
6. See Fig. 11 for location of all switch sections.
7. Values and tolerances are nominal and variations may be found. It is recommended that the value of any replacement correspond to the nominal value of the part being replaced.

\perp Chassis

- * Band selector switch contacts marked with * indicates these contacts are internally connected to the same numbered contacts on the other half of the switch wafer section.

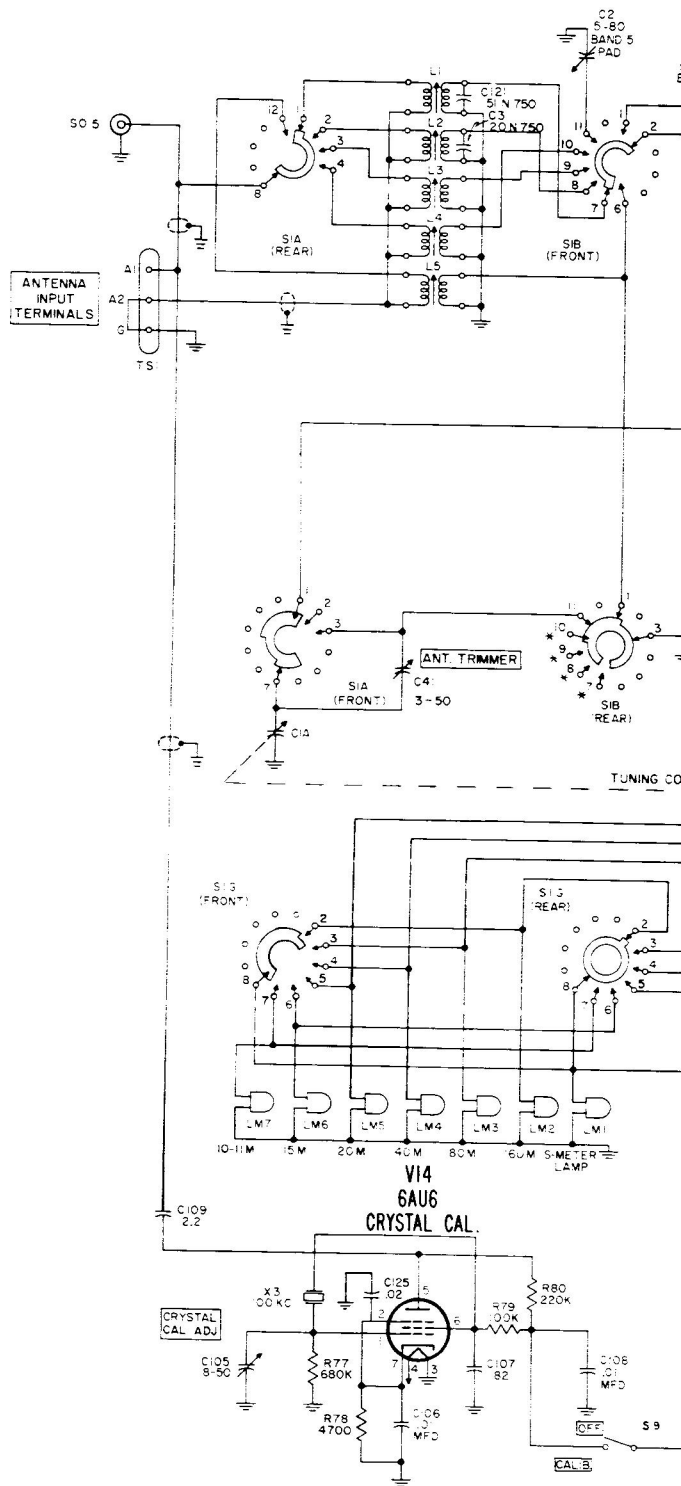

LAST "C" SYMBOL C141
LAST "R" SYMBOL R 97

Warranty

"The Hallicrafter's Company warrants each new radio product manufactured by it to be free from defective material and workmanship and agrees to remedy any such defect or to furnish a new part in exchange for any part of any unit of its manufacture which under normal installation, use and service discloses such defect, provided the unit is delivered by the owner to our authorized radio dealer, wholesaler, from whom purchased, or, authorized service center, intact, for examination, with all transportation charges prepaid within ninety days from the date of sale to original purchaser and provided that such examination discloses in our judgment that it is thus defective.

This warranty does not extend to any of our radio products which have been subjected to misuse, neglect, accident, incorrect wiring not our own, improper installation, or to use in violation of instructions furnished by us, nor extend to units which have been repaired or altered outside of our factory or authorized service center, nor to cases where the serial number thereof has been removed, defaced or changed, nor to accessories used therewith not of our own manufacture.

Any part of a unit approved for remedy or exchange hereunder will be remedied or exchanged by the authorized radio dealer or wholesaler without charge to the owner.

This warranty is in lieu of all other warranties expressed or implied and no representative or person is authorized to assume for us any other liability in connection with the sale of our radio products."

Form No. 94X622

the Hallicrafters co.

K4XL's **BAMA**

This manual is provided **FREE OF CHARGE** from the "BoatAnchor Manual Archive" as a service to the Boatanchor community.

It was uploaded by someone who wanted to help you repair and maintain your equipment.

If you paid anyone other than BAMA for this manual, you paid someone who is making a profit from the free labor of others without asking their permission.

You may pass on copies of this manual to anyone who needs it. But do it without charge.

Thousands of files are available without charge from BAMA. Visit us at <http://bama.sbc.edu>